

# AEROVENT

INDUSTRIAL VENTILATION SYSTEMS



## **MARINE DUTY TUBEAXIAL & VANEAXIAL FANS**

**Direct Drive**

**Model MDTM / MDVM / MDVH**

## Models

**MDTM | MDVM | MDVH**

**Aerovent's Marine Duty Fans feature medium and high static pressure capabilities from 0" to 5" and air volumes to 127,000 CFM. Marine Duty Fans offer a heavy duty, compact design for various marine duty applications such as:**

- Machinery ventilation
- General bulkhead ventilation
- Cargo hold ventilation
- Engine room ventilation
- Heating and air conditioning



### Vessels equipped with Aerovent Marine Duty Fans:

- Gas and oil platforms
- Drilling rigs
- Supply ships
- Tug boats
- Casino boats
- Cruise ships
- Ferry boats

### Hibernia oil platform



Located offshore of Newfoundland in the North Atlantic Ocean, the Hibernia oil platform utilizes 54 Aerovent Marine Duty Fans for its HVAC systems. The Hibernia oil platform is on the fifth largest oilfield ever discovered in Canada, managed and operated by Hibernia Management & Development Company, Ltd. Estimates of recoverable oil reserves range between 525 million and 666 million barrels.

The Hibernia Management & Development Company, Ltd. selected suppliers with strict performance measures to maintain their high environmental, safety and operating standards.

Aerovent is proud to be one of Hibernia's suppliers.

*Hibernia oil platform photograph is courtesy of Hibernia Management & Development Company, Ltd. who manages and operates this platform.*

### Trump Casino Vessel



The Trump Casino, one of the top-rated passenger and casino vessels, is the home of 42 Aerovent Marine Duty Fans. The compact design and quiet operation of the fans make them ideal for below deck service of the vessel's supply and exhaust system.

Atlantic Marine, Inc., the shipbuilder of the Trump Casino, selected Aerovent based on their proven performance and reliability on several other passenger vessel projects where Marine Duty Vaneaxial Fans have been installed.



©2000 Aerovent, Twin City Fan Companies, Ltd.  
Catalog illustrations cover the general appearance of Aerovent products at the time of publication and we reserve the right to make changes in design and construction at any time without notice.

## Model MDTM – Marine Duty Tubeaxial Medium Pressure

## Model MDVM – Marine Duty Vaneaxial Medium Pressure

## Model MDVH – Marine Duty Vaneaxial High Pressure

Aerovent's Marine Duty Tubeaxial and Vaneaxial Fans are specifically designed for the marine duty market. Housing lengths have been shortened from our standard tubeaxial and vaneaxial fans to offer a compact design and minimize the installation space required. In addition, housings are constructed of heavy gauge steel to permit hot dip galvanizing for corrosion resistance against salt and water spray. Aerovent also offers TEFC and Explosion Proof motors that are suitable for severe marine environments that meet IEEE 45, below deck service.

- Sizes available 12" through 60".
- Performance Ranges:
  - MDTM – Capacity from 835 to 102,000 CFM, pressures to 3" SP
  - MDVM – Capacity from 1,870 to 104,000 CFM, pressures to 4" SP
  - MDVH – Capacity from 1,870 to 127,000 CFM, pressures to 5" SP
- Housings constructed of heavy gauge steel and continuously welded to ensure long life.
- Housing flanges are designed to ensure concentricity, strengthen the housing and permit duct mounting.
- Motor wiring is extended through liquid-tight conduit to the outside of the housing for easy connection.
- Lubrication lines from the motor bearings are extended to the outside of the fan housing, where required by motor design, for easy maintenance.
- Models MDVM and MDVH feature a bolt-on guide vane section designed to obtain higher efficiencies and to minimize turbulence downstream from the fan.
- Motors suitable for severe marine environments that meet IEEE 45 below deck service are available as an option.



## Propeller Design

Marine duty fans use a one-piece cast aluminum propeller with fixed pitch blades. The blades can be cut to one of several diameters in order to provide various hub-to-tip ratios. Varying hub-to-tip ratios allow for different pressure and efficiency characteristics and the option of having several different wheels (different hub ratios) for a set diameter.

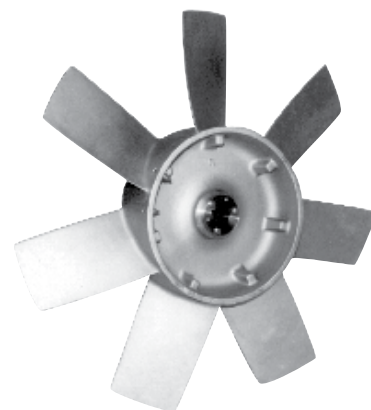

# Fan Selection

Present methods of testing fans provide accurate, dependable performance data; however, information available for designing systems is necessarily based on averages.

Therefore, a certain amount of “rounding off” of design figures is a reasonable approach and will produce a practical air handling system design. Most engineers prefer the static pressure or friction loss method of calculation.

The fan is usually located somewhere within the system; therefore, it is only necessary to figure the entrance loss and the duct friction loss, then select the fan directly from the tables. This method assumes that the duct size from the outlet of the fan to where the air is released to atmosphere is essentially the same as the diameter of the fan.

- If the fan is at the beginning of the duct, then an inlet bell should be used and no entrance loss is calculated.
- If the fan is at the end of the duct, then the entrance loss and duct friction are calculated and this is the fan static pressure.
- If an outlet cone is used and there is a static regain, the regain can be added to the static pressure. For information on how to calculate the static pressure regain, see Outlet Cones in the accessory section.

Some systems are designed using total pressure (TP). Using the following formulas, the total pressure can be calculated.

## Fan Selection Formulas

$VP = \left( \frac{CFM}{AREA \times 4005} \right)^2$	<b>NOTE:</b> This formula is used only for density at standard air, 0.075 lbs./ft <sup>3</sup> , 70°F and sea level.	<b>Where:</b> VP = Velocity pressure, IWG SP = Static pressure, IWG TP = Total pressure, IWG OV = Fan outlet velocity, FPM AREA = Fan outlet area, Ft <sup>2</sup>
$VP = \left( \frac{CFM}{AREA \times 1096.7} \right)^2 \times \text{Density in lbs.per ft}^3$	<b>NOTE:</b> This formula is used when density is other than standard.	
$TP = VP + SP$		
$OV = \left( \frac{CFM}{AREA} \right)$		

## Motor Selection

Motors furnished on direct drive fans standardly have a T-frame, 1.15 service factor, and are good for applications up to 105°F. Many enclosures are available such as open drip-proof, totally enclosed fan cooled and explosion proof.

Direct drive fan motors have an increased service factor due to the high air velocity over the motor. However, it is good practice when selecting motor horsepower (MHP) that the required brake horsepower (BHP) not exceed MHP x 1.10. If the required BHP exceeds MHP x 1.10, the next higher MHP should be selected.

**Example A:** If the required fan BHP is 10.2, first check a 10 HP motor. Since 10 HP x 1.10 (= 11.0) is greater than 10.2, then a 10 HP motor could be used.

**Example B:** If the required fan BHP is 11.1, first check a 10 HP motor. Since 10 HP x 1.10 (= 11.0) is less than 11.1, then the next higher horsepower should be selected, a 15 HP.

Aerovent's Marine Duty fans standardly are cleaned and chemically pretreated by a phosphatizing process and then coated with an alkyd primer and an air dry enamel top coat.

For marine duty applications where corrosion resistance against salt and water spray is needed, Aerovent offers hot dip galvanizing as an option. Hot dip galvanizing protects steel by metallurgically bonding the zinc to the steel forming a barrier coating with many layers. These layers protect the steel from scratches. If the barrier coating ever becomes damaged, the zinc coating sacrifices itself (i.e., cathodic action) to protect the steel.

Aerovent's Marine Duty fans can be protected with a variety of other suitable coatings, such as:

- Epoxy
- Plasite
- Farboil
- Heresite
- Dimetcote Inorganic Zinc

## Drive Arrangements

Following are the mounting arrangements for the direct drive Marine Duty models MDTM, MDVM, and MDVH.

**Example 1:** For mounting arrangement, horizontal floor mounted, specify "HBM."

**Example 2:** For mounting arrangement, floor down discharge, specify "A6."

## Direct Drive Fans

### Horizontal Floor

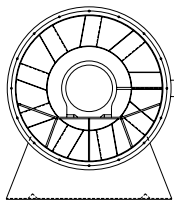

Support Legs  
(HBM)

### Ceiling Horizontal Discharge

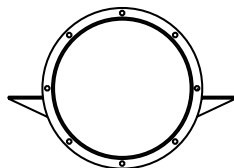

A13

### Vertical Floor & Ceiling Mounted

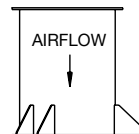

Floor  
Down  
Discharge  
(A5)

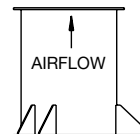

Floor  
Up  
Discharge  
(A6)

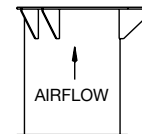

Ceiling  
Up  
Discharge  
(A7)

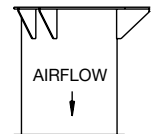

Ceiling  
Down  
Discharge  
(A8)

# Accessories



*Bolted  
Inspection Door*



*Propeller Access  
Section*



*Support Legs*

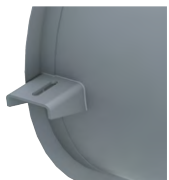

*Horizontal  
Mounting Clips*

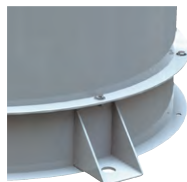

*Vertical  
Mounting Clips*



*Spring Type Isolators*



*RIS Type Isolators*



*Companion Flange*

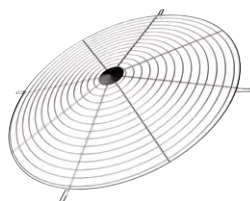

*Inlet/Outlet Guard*

## **Bolted Inspection Door**

The bolted inspection door (not shown) allows limited access to inspect the internal parts of the fan. If access for cleaning is required use the "Propeller Access Section."

## **Propeller Access Section**

The propeller access section is a short duct section that bolts to the fan inlet or outlet and includes a hinged inspection door. Half the access section can be removed or the hinged inspection door can be opened to permit inspection or cleaning of the fan propeller.

## **Support Legs**

Support legs are available for standard platform or floor mounting. The support legs are bolted to the inlet and outlet flange.

## **Horizontal Ceiling Clips**

### **Vertical Mounting Clips**

Clips are recommended to permit easy installation and when using vibration isolators. Horizontal ceiling clips are welded to the fan housing.

Vertical mounting clips can be welded to the fan housing.

## **Vibration Isolators**

Rubber-in-shear and spring type isolators are available for floor or ceiling mounting, as follows:

*RIS Floor* — Rubber-in shear, for floor mounting

*RIS Ceiling* — Rubber-in-shear, for ceiling mounting

*Spring Floor* — Spring type, for floor mounting

*Spring Ceiling* — Spring type, for ceiling mounting

## **Companion Flanges**

Companion flanges are rolled angle rings that match the fan inlet and outlet flanges to provide easy attachment for slip duct connections.

## **OSHA Inlet and Outlet Guards**

Inlet and outlet guards are offered to protect personnel from the moving parts. Recommended for use when no ductwork is attached to the inlet and/or outlet. Fan sizes 12" through 60" are supplied with spiral wire type PMS guards.

## **Inlet Bell**

An inlet bell is recommended on the inlet side of the fan to minimize entrance losses for installations where the fan inlet is not attached to a duct system.

# Accessories

## Silencers

Silencers are designed to reduce fan noise with only minor resistance to airflow. Aerovent silencers and vaneaxial fans provide an aerodynamically and acoustically matched package.

Flange connections on both the inlet and outlet ends provide easy mounting to the vaneaxial fan. Silencers can be added to both the fan inlet and outlet for the most critical noise applications.

Silencer Resistance Chart

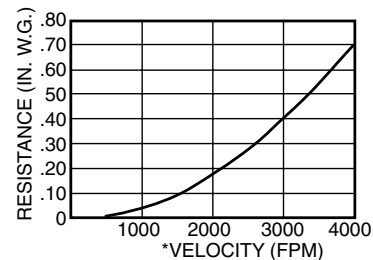

\* Velocity at the silencer inlet.  
Velocity at the silencer outlet is 1.33 x inlet velocity.

Silencer Insertion Loss (dB's)

OCTAVE BAND TO FREQ. (HZ)	20 TO 75	75 TO 150	140 TO 300	300 TO 600	600 TO 1200	1200 TO 2400	2400 TO 4800	4800 TO 10000
INSERTION LOSS (EA. SILENCER)	5	5	12	18	22	18	17	15

## Inlet and Outlet Cones

Inlet and outlet cones offer a round-to-round transition from the fan inlet and/or outlet to the specific duct diameter of the system.

If a standard outlet cone is used, the static pressure regain can be added to the fan static pressure. The approximate additional static pressure capability is shown in the following chart. Add the amount shown to the fan static pressure and then enter the performance tables to select the fan.

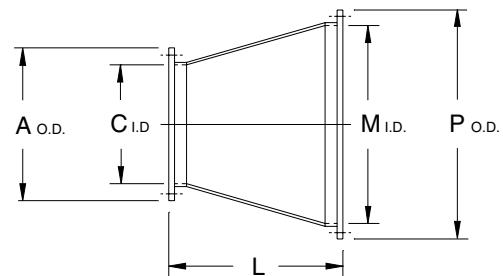

Dimensions are not to be used for construction.

For MDTM & MDVM Fans Only

FAN SIZE	CONE DIMENSIONS					AREA (FT <sup>2</sup> )	
	A	C	M	P	L	C-side	M-side
12	16 <sup>9</sup> / <sub>32</sub>	12 <sup>9</sup> / <sub>32</sub>	16 <sup>3</sup> / <sub>8</sub>	18 <sup>7</sup> / <sub>8</sub>	15	0.82	1.46
16	20 <sup>9</sup> / <sub>32</sub>	16 <sup>9</sup> / <sub>32</sub>	21 <sup>5</sup> / <sub>16</sub>	24 <sup>5</sup> / <sub>16</sub>	18	1.45	2.48
18	22 <sup>9</sup> / <sub>32</sub>	18 <sup>9</sup> / <sub>32</sub>	24 <sup>5</sup> / <sub>16</sub>	27 <sup>5</sup> / <sub>16</sub>	19	1.82	3.22
24	29 <sup>3</sup> / <sub>8</sub>	24 <sup>3</sup> / <sub>8</sub>	29 <sup>9</sup> / <sub>16</sub>	32 <sup>9</sup> / <sub>16</sub>	21	3.24	4.77
28	33 <sup>3</sup> / <sub>8</sub>	28 <sup>3</sup> / <sub>8</sub>	33 <sup>11</sup> / <sub>16</sub>	37 <sup>11</sup> / <sub>16</sub>	21	4.39	6.19
32	37 <sup>1</sup> / <sub>2</sub>	32 <sup>1</sup> / <sub>2</sub>	38 <sup>11</sup> / <sub>16</sub>	42 <sup>11</sup> / <sub>16</sub>	23	5.76	8.16
36	41 <sup>1</sup> / <sub>2</sub>	36 <sup>1</sup> / <sub>2</sub>	42 <sup>7</sup> / <sub>16</sub>	46 <sup>7</sup> / <sub>16</sub>	23	7.27	9.82
40	45 <sup>1</sup> / <sub>2</sub>	40 <sup>1</sup> / <sub>2</sub>	48 <sup>15</sup> / <sub>16</sub>	52 <sup>15</sup> / <sub>16</sub>	24	8.95	13.06
44	49 <sup>1</sup> / <sub>2</sub>	44 <sup>1</sup> / <sub>2</sub>	52 <sup>5</sup> / <sub>32</sub>	56 <sup>5</sup> / <sub>32</sub>	24	10.80	14.84
48	54 <sup>3</sup> / <sub>8</sub>	48 <sup>3</sup> / <sub>8</sub>	55	59	24	12.90	16.50
54	61 <sup>1</sup> / <sub>8</sub>	55 <sup>1</sup> / <sub>8</sub>	61	65	24	16.57	20.29
60	67 <sup>1</sup> / <sub>8</sub>	61 <sup>1</sup> / <sub>8</sub>	67 <sup>1</sup> / <sub>4</sub>	72 <sup>1</sup> / <sub>4</sub>	24	20.38	24.67

FAN OUTLET VELOCITY (FPM)	STATIC PRESSURE REGAIN (INCHES W.G.)
1000	.025
1400	.042
1800	.078
2200	.113
2600	.151
3000	.216
3400	.273
3800	.341
4200	.419
4600	.494
5000	.576

For MDVH Fans Only

FAN SIZE	CONE DIMENSIONS					AREA (FT <sup>2</sup> )	
	A	C	M	P	L	C-side	M-side
12	15 <sup>3</sup> / <sub>4</sub>	12 <sup>3</sup> / <sub>4</sub>	16 <sup>3</sup> / <sub>8</sub>	18 <sup>7</sup> / <sub>8</sub>	13	0.89	1.46
18	21 <sup>3</sup> / <sub>4</sub>	18 <sup>3</sup> / <sub>4</sub>	24 <sup>5</sup> / <sub>16</sub>	27 <sup>5</sup> / <sub>16</sub>	19	1.92	3.22
21	24 <sup>3</sup> / <sub>4</sub>	21 <sup>3</sup> / <sub>4</sub>	27 <sup>5</sup> / <sub>16</sub>	30 <sup>5</sup> / <sub>16</sub>	22	2.58	4.07
26	30 <sup>3</sup> / <sub>4</sub>	26 <sup>3</sup> / <sub>4</sub>	33	36	23	3.90	5.94
29	33 <sup>3</sup> / <sub>4</sub>	29 <sup>3</sup> / <sub>4</sub>	36 <sup>7</sup> / <sub>16</sub>	40 <sup>7</sup> / <sub>16</sub>	23	4.83	7.24
36	40 <sup>3</sup> / <sub>4</sub>	36 <sup>3</sup> / <sub>4</sub>	42 <sup>7</sup> / <sub>16</sub>	46 <sup>7</sup> / <sub>16</sub>	23	7.37	9.82
42	46 <sup>3</sup> / <sub>4</sub>	42 <sup>3</sup> / <sub>4</sub>	48 <sup>15</sup> / <sub>16</sub>	52 <sup>15</sup> / <sub>16</sub>	24	9.97	13.06
48	54	50	55	59	24	18.99	16.50
54	60 <sup>3</sup> / <sub>8</sub>	55 <sup>3</sup> / <sub>8</sub>	61	65	24	16.72	20.29
60	66 <sup>3</sup> / <sub>8</sub>	61 <sup>3</sup> / <sub>8</sub>	67 <sup>1</sup> / <sub>4</sub>	72 <sup>1</sup> / <sub>4</sub>	24	20.55	24.67



## Direct Drive – Model MDTM

### Catalog Numbering System

To identify a specific fan for ordering or engineering specifications, it is necessary to show the complete information listed in the tables below under catalog number. All performance data is available in curve form upon request.

All capacities shown in the performance tables that follow are for standard air conditions: 70°F at sea level (0.075 lbs./cu.ft. air density).

The performance tables shown are given in English units.

**12 D6 40 MDTM 3450 1**

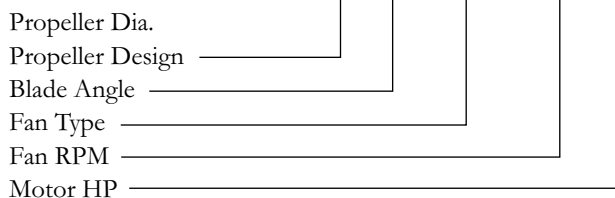

### Model MDTM – Marine Duty Tubeaxial Medium Pressure

CATALOG NUMBER				0" SP		0.5" SP		1" SP		1.5" SP		2" SP		2.5" SP		3" SP	
PROP	FAN TYPE	RPM	HP	CFM	BHP	CFM	BHP	CFM	BHP	CFM	BHP	CFM	BHP	CFM	BHP	CFM	BHP
12D640	MDTM	1750	1/4	1304	0.10	867	0.14										
	MDTM	3450	1	2570	0.73	2387	0.84	2178	0.94	1943	1.01						
16D440	MDTM	3450	3	5917	1.68	5594	1.92	5238	2.15	4835	2.34	4402	2.49	3833	2.56		
16D540	MDTM	1750	1/2	3229	0.30	2530	0.42										
	MDTM	3500	5	6458	2.40	6195	2.59	5891	2.82	5493	3.12	5061	3.39	4707	3.48	4270	3.56
18D440	MDTM	1170	1/4	2854	0.12												
	MDTM	1750	1/2	4268	0.39	3465	0.55										
	MDTM	3500	5	8536	3.13	8202	3.49	7835	3.83	7416	4.15	6930	4.42	6429	4.63	5869	4.77
24D440	MDTM	1750	3	10395	1.81	9469	2.21	8232	2.59	6793	2.74						
24D540	MDTM	1170	1	7287	0.68	5749	0.96										
24D640	MDTM	1750	5	10804	2.81	10043	3.22	9108	3.66	8067	3.97						
24D740	MDTM	1170	1 1/2	6575	0.98	5537	1.26										
28D540	MDTM	1170	2	11571	1.47	9922	1.91	7736	2.17								
	MDTM	1750	7 1/2	17308	4.91	16338	5.52	15174	6.19	13718	6.89	12327	7.17				
32D440	MDTM	1170	5	16474	2.28	14559	2.92	11969	3.40								
	MDTM	1750	15	24640	7.63	23466	8.59	22131	9.54	20491	10.49	18749	11.17	16852	11.52		
32D540	MDTM	1750	15	25835	9.58	24746	10.48	23518	11.43	22021	12.53	20348	13.48	18778	13.91	16974	14.19
36D440	MDTM	1170	7 1/2	23633	4.23	21582	5.13	18824	6.01	15692	6.39						
	MDTM	1750	20	35348	14.16	34060	15.52	32641	16.86	31024	18.22	29092	19.6	27143	20.57	25129	21.13
40D440	MDTM	870	5	23708	2.77	20524	3.62	15576	4.19								
	MDTM	1170	10	31882	6.73	29816	7.86	26911	9.06	23458	9.92	18985	10.18				
	MDTM	1750	30	47688	22.51	46388	24.19	44959	25.89	43351	27.6	41390	29.41	38933	31.24	36660	32.53
40D540	MDTM	1170	15	33813	8.73	31825	9.72	29212	11.09	25948	12.47	22761	12.92				
44D440	MDTM	870	10	33408	5.78	30120	7.03	25795	8.25	20863	8.61						
	MDTM	1170	20	44928	14.05	42613	15.71	39962	17.43	36712	19.33	33445	20.35	29852	20.85		
48D440	MDTM	1750	60	67200	47.00	65702	49.47	64124	51.97	62454	54.5	60672	57.08	58709	59.84	56524	62.79
	MDTM	870	10	41342	7.12	37610	8.72	32623	10.21	26773	10.79						
	MDTM	1170	30	55598	17.32	52963	19.49	49972	21.61	46304	23.77	42394	25.31	38160	26.13		
54D340	MDTM	1750	75	83160	57.97	81452	61.22	79658	64.45	77764	67.65	75749	70.83	73569	74.01	71123	77.29
	MDTM	695	10	44586	5.50	38943	7.28	31155	8.38								
	MDTM	870	15	55812	10.78	51557	13.16	46299	14.98	39982	16.34						
54D440	MDTM	1170	40	75058	26.23	72010	29.54	68669	32.56	64889	35.13	60562	37.18	55927	39.09	50444	40.16
	MDTM	870	20	59311	13.21	55268	15.48	50162	17.79	44251	19.43	37246	19.97				
60D340	MDTM	695	15	61160	9.31	55092	11.85	47157	13.61								
	MDTM	870	30	76560	18.26	71909	21.57	66479	24.35	59954	26.43	52349	27.94				
	MDTM	1170	60	102960	44.42	99601	48.99	95993	53.26	92067	57.14	87643	60.38	82767	63.12	77646	65.77

\*IEEE4S and USCG 259 Marine Duty (below deck) motors require a minimum of 1 HP.  
 Performance shown is for installation type B: Free inlet, ducted outlet.  
 Performance ratings do not include the effect of appurtenances in the airstream.



## Direct Drive – Model MDVM

### Catalog Numbering System

To identify a specific fan for ordering or engineering specifications, it is necessary to show the complete information listed in the tables below under catalog number. All performance data is available in curve form upon request.

All capacities shown in the performance tables that follow are for standard air conditions: 70°F at sea level (0.075 lbs./cu.ft. air density).

The performance tables shown are given in English units.

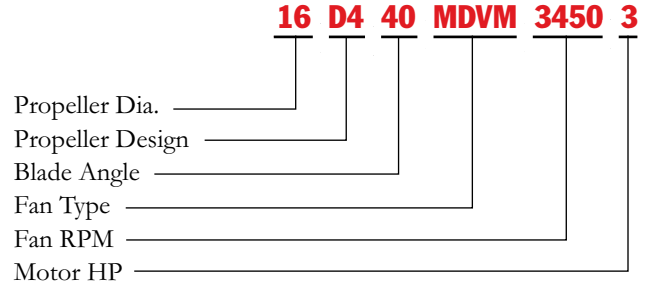

### Model MDVM – Marine Duty Vaneaxial Medium Pressure

CATALOG NUMBER				1" SP		1.5" SP		2" SP		2.5" SP		3" SP		3.5" SP		4" SP	
PROP	FAN TYPE	RPM	HP	CFM	BHP	CFM	BHP	CFM	BHP	CFM	BHP	CFM	BHP	CFM	BHP	CFM	BHP
12D640	MDVM	3450	1	2428	0.89	2272	0.96	2092	1.02	1868	1.08						
16D440	MDVM	3450	3	5457	2.20	5108	2.40	4690	2.55	4162	2.64						
16D540	MDVM	3500	5	6177	2.88	5925	3.06	5633	3.27	5300	3.47	4931	3.64	4473	3.75		
18D440	MDVM	3500	5	8121	3.89	7773	4.21	7354	4.49	6875	4.72	6346	4.92	5737	5.02		
24D540	MDVM	1750	5	9656	2.83	8621	3.18	7282	3.37								
24D640	MDVM	1170	1½	5276	1.19												
	MDVM	1750	5	9978	3.23	9257	3.58	8384	3.87	7200	4.04						
24D740	MDVM	1750	5	9464	3.53	8942	3.85	8337	4.12	7623	4.36	6639	4.51				
	MDVM	1170	2	7107	1.71												
28D440	MDVM	1750	7½	14656	4.73	13254	5.27	11562	5.64								
	MDVM	1170	2	8796	2.10												
28D540	MDVM	1750	7½	16015	5.71	15030	6.28	13798	6.83	12360	7.20						
	MDVM	1170	3	12871	3.27												
32D440	MDVM	1750	15	22936	8.94	21699	9.81	20076	10.62	18259	11.25	16084	11.55				
	MDVM	1170	7½	20147	5.64	17177	6.27										
36D440	MDVM	1750	20	33599	15.81	32390	17.06	30948	18.29	29157	19.47	27221	20.44	25027	21.15	22429	21.40
	MDVM	870	5	16959	4.12												
40D440	MDVM	1170	10	28296	8.55	25088	9.52	21084	10.20								
	MDVM	1750	40	45820	24.4	44548	26.15	43111	27.84	41325	29.43	39124	30.87	36857	32.25	34361	33.46
40D640	MDVM	870	7½	21413	5.53	18427	6.15										
	MDVM	1170	15	31605	11.79	29953	12.82	28027	13.84	25851	14.68	22834	15.24				
	MDVM	870	10	28114	7.70	24181	8.47										
44D440	MDVM	1170	20	41782	16.24	39511	17.75	36700	19.28	33845	20.29	30331	20.86				
	MDVM	1750	60	65638	48.95	64421	51.12	63133	53.30	61761	55.49	60274	57.73	58591	60.09	56730	62.47
44D540	MDVM	870	10	29959	8.37	26565	9.50	22496	10.06								
	MDVM	1170	25	43138	18.10	41496	19.44	39403	21.00	36786	22.61	34286	23.63	31244	24.34	26526	24.44
	MDVM	870	10	34841	9.62	29282	10.65										
48D440	MDVM	1170	25	51782	20.26	49016	22.24	45388	24.07	41326	25.49	36478	26.21				
	MDVM	1750	75	81212	60.25	79763	63.32	78221	66.36	76566	69.36	74760	72.32	72685	75.24	70313	78.06
	MDVM	695	10	32521	8.13												
54D340	MDVM	870	15	48245	14.38	41696	15.79										
	MDVM	1170	40	70555	30.40	67340	33.48	63143	35.75	58315	37.66	52894	39.19	47014	39.83		
	MDVM	695	10	37462	9.57												
54D440	MDVM	1170	50	75841	35.85	73135	38.67	69916	41.45	65914	44.11	61581	46.33	56683	47.94	50902	48.57
	MDVM	695	15	49161	13.09	38893	14.13										
60D340	MDVM	870	30	68944	23.18	62489	25.41	54755	27.17								
	MDVM	1170	75	98279	49.33	94988	53.83	91138	57.76	86292	60.71	80962	63.33	75084	65.66	68815	67.10

\*IEEE4S and USCG 259 Marine Duty (below deck) motors require a minimum of 1 HP.  
 Performance shown is for installation type B: Free inlet, ducted outlet.  
 Performance ratings do not include the effect of appurtenances in the airstream.

## Direct Drive – Model MDVH

### Catalog Numbering System

To identify a specific fan for ordering or engineering specifications, it is necessary to show the complete information listed in the tables below under catalog number. All performance data is available in curve form upon request.

All capacities shown in the performance tables that follow are for standard air conditions: 70°F at sea level (0.075 lbs./cu.ft. air density).

The performance tables shown are given in English units.

**26 D5 40 MDVH 1750 5**

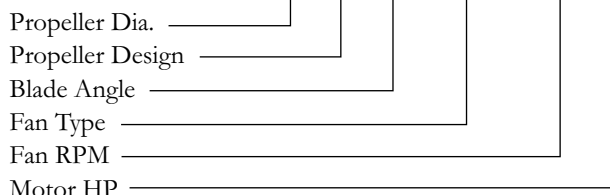

### Model MDVH – Marine Duty Vaneaxial High Pressure

CATALOG NUMBER				0" SP		0.5" SP		1" SP		1.5" SP		2" SP		2.5" SP		3" SP	
PROP	FAN TYPE	RPM	HP	CFM	BHP	CFM	BHP	CFM	BHP	CFM	BHP	CFM	BHP	CFM	BHP	CFM	BHP
12D640	MDVH	3450	1	2694	0.72	2568	0.80	2428	0.89	2272	0.96	2092	1.02	1868	1.08		
18D640	MDVH	3500	7½	9457	5.45	9256	5.71	9046	5.98	8825	6.25	8593	6.51	8346	6.78	8081	7.05
21D540	MDVH	3500	15	14952	9.82	14677	10.26	14390	10.69	14088	11.12	13770	11.55	13431	11.98	13064	12.42
26D540	MDVH	1750	7½	14280	3.94	13715	4.36	13093	4.77	12389	5.20	11567	5.64	10585	5.97	9246	6.19
29D540	MDVH	1750	10	19600	6.43	19010	6.95	18354	7.49	17601	8.07	16639	8.75	15498	9.39	14309	9.78
36D640	MDVH	1170	10	24991	5.84	23844	6.58	22530	7.33	20919	8.11	18967	8.78	16345	9.17		
	MDVH	1750	30	37380	19.53	36638	20.64	35856	21.75	35027	22.86	34142	23.98	33184	25.11	32118	26.29
42D540	MDVH	1750	50	59106	35.27	58092	37.03	57024	38.81	55893	40.60	54686	42.41	53387	44.25	51944	46.16
	MDVH	1170	20	39830	12.38	38476	13.54	36986	14.71	35301	15.91	33289	17.19	30979	18.31	28259	19.14
42D640	MDVH	1750	60	59575	41.43	58692	43.16	57773	44.89	56816	46.64	55813	48.40	54759	50.16	53644	51.95
	MDVH	1170	30	58987	20.55	57221	22.31	55278	24.10	53091	25.93	50452	27.90	47305	29.82	43864	31.26
48D540	MDVH	1750	100	88228	68.77	87076	71.40	85878	74.04	84630	76.70	83323	79.38	81950	82.08	80499	84.81
	MDVH	1170	60	85430	52.65	82735	54.23	79955	55.77	77082	57.24	74129	58.71	71064	60.10	67772	61.17
54T734	MDVH	1750	200	127780	176.16	125993	178.56	124182	180.93	122346	183.25	120484	185.54	118594	187.79	116676	190.00
60T734	MDVH	1170	100	117000	88.97	114166	91.28	111247	93.50	108234	95.62	105118	97.64	101918	99.60	98604	101.47

CATALOG NUMBER				3.5" SP		4" SP		4.5" SP		4.5" SP	
PROP	FAN TYPE	RPM	HP	CFM	BHP	CFM	BHP	CFM	BHP	CFM	BHP
12D640	MDVH	3450	1								
18D640	MDVH	3500	7½	7795	7.31	7491	7.56	7168	7.79	6806	8.00
21D540	MDVH	3500	15	12663	12.86	12231	13.29	11778	13.69	11301	14.08
26D540	MDVH	1750	7½								
29D540	MDVH	1750	10	12707	10.03						
36D640	MDVH	1170	10								
	MDVH	1750	30	30938	27.45	29668	28.51	28296	29.41	26746	30.16
42D540	MDVH	1750	50	50296	48.19	48470	50.17	46568	51.88	44547	53.30
	MDVH	1170	20								
42D640	MDVH	1750	60	52444	53.79	51134	55.70	49717	57.60	48211	59.41
	MDVH	1170	30	39698	32.17						
48D540	MDVH	1750	100	78952	87.58	77248	90.49	75361	93.51	73310	96.52
	MDVH	1170	60	64339	61.79	60210	61.82				
54T734	MDVH	1750	200	114729	192.17	112762	194.35	110774	196.55	108753	198.71
60T734	MDVH	1170	100	95076	103.03	91253	104.02	87176	104.38	82035	103.91

\*IEEE4S and USCG 259 Marine Duty (below deck) motors require a minimum of 1 HP.  
 Performance shown is for installation type B: Free inlet, ducted outlet.  
 Performance ratings do not include the effect of appurtenances in the airstream.

## Model MDTM Direct Drive Marine Duty Tubeaxial

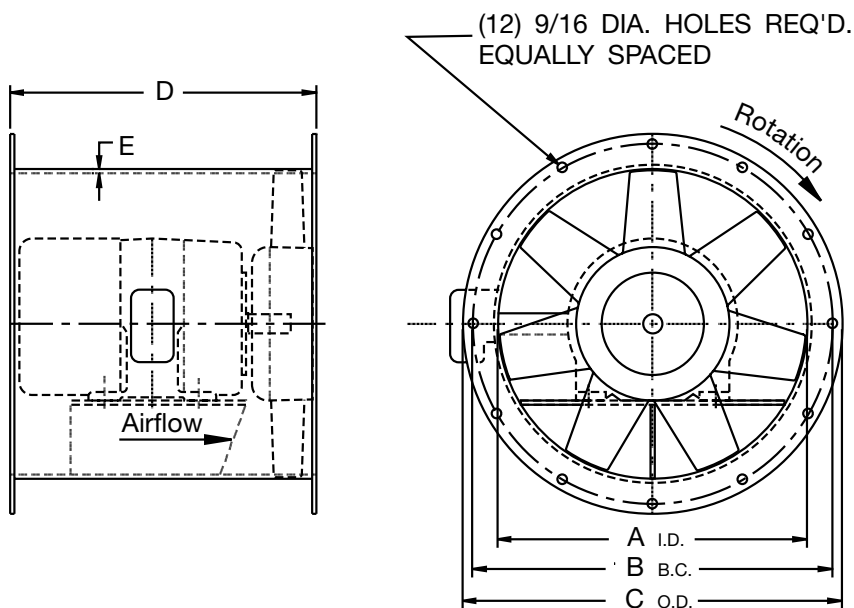

SIZE	A	B	C	D	E	MAX. MOTOR FRAME	HUB SIZE
12	12 <sup>5</sup> / <sub>32</sub>	15 <sup>1</sup> / <sub>8</sub>	16 <sup>9</sup> / <sub>32</sub>	15	1/4	145T	D6
16	16 <sup>5</sup> / <sub>32</sub>	19 <sup>1</sup> / <sub>8</sub>	20 <sup>9</sup> / <sub>32</sub>	18	1/4	184T	D5
18	18 <sup>5</sup> / <sub>32</sub>	21 <sup>1</sup> / <sub>8</sub>	22 <sup>9</sup> / <sub>32</sub>	18	1/4	184T	D4
24	24 <sup>3</sup> / <sub>16</sub>	27 <sup>5</sup> / <sub>8</sub>	29 <sup>3</sup> / <sub>8</sub>	23	1/4	184T	D7
28	28 <sup>1</sup> / <sub>4</sub>	31 <sup>3</sup> / <sub>8</sub>	33 <sup>3</sup> / <sub>8</sub>	23	1/4	215T	D5
32	32 <sup>1</sup> / <sub>4</sub>	35 <sup>3</sup> / <sub>4</sub>	37 <sup>1</sup> / <sub>2</sub>	28	1/4	256T	D5
36	36 <sup>1</sup> / <sub>4</sub>	39 <sup>3</sup> / <sub>4</sub>	41 <sup>1</sup> / <sub>2</sub>	28	1/4	256T	D4
40	40 <sup>3</sup> / <sub>8</sub>	43 <sup>3</sup> / <sub>4</sub>	45 <sup>1</sup> / <sub>2</sub>	34	1/4	286T	D6
44	44 <sup>3</sup> / <sub>8</sub>	47 <sup>3</sup> / <sub>4</sub>	49 <sup>1</sup> / <sub>2</sub>	37	1/4	365T	D4
48	48 <sup>3</sup> / <sub>8</sub>	52 <sup>3</sup> / <sub>8</sub>	54 <sup>3</sup> / <sub>8</sub>	37	1/4	365T	D4
54	54 <sup>3</sup> / <sub>8</sub>	59	61 <sup>1</sup> / <sub>8</sub>	40	3/8	365T	D4
60	60 <sup>3</sup> / <sub>8</sub>	65	67 <sup>1</sup> / <sub>8</sub>	41	3/8	404T	D3

Dimensions are not to be used for construction.

## Model MDVM Direct Drive Marine Duty Vaneaxial

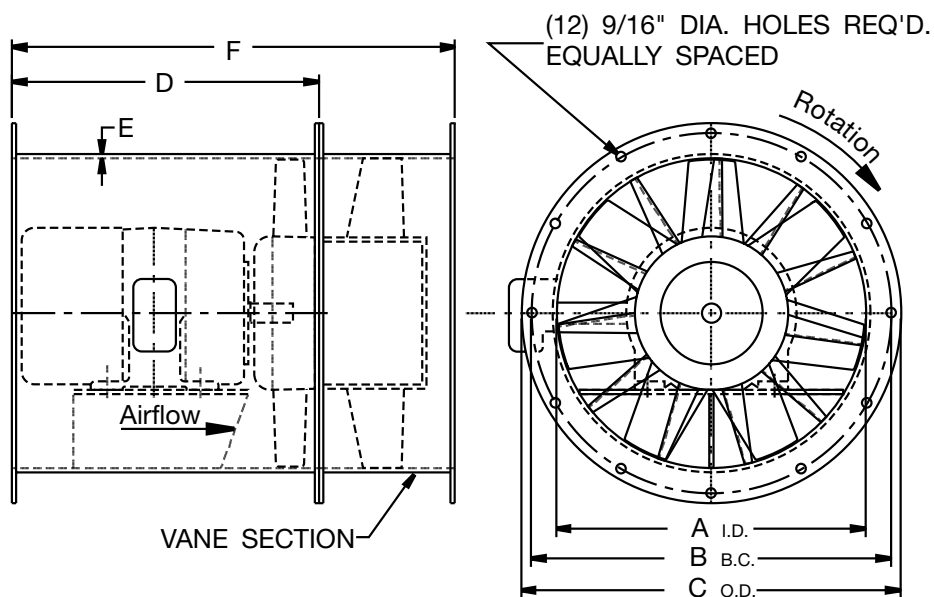

SIZE	A	B	C	D	E	F	MAX. MOTOR FRAME	HUB SIZE
12	12 <sup>5</sup> / <sub>32</sub>	15 <sup>1</sup> / <sub>8</sub>	16 <sup>9</sup> / <sub>32</sub>	15	1/4	21	145T	D6
16	16 <sup>5</sup> / <sub>32</sub>	19 <sup>1</sup> / <sub>8</sub>	20 <sup>9</sup> / <sub>32</sub>	18	1/4	25	184T	D5
18	18 <sup>5</sup> / <sub>32</sub>	21 <sup>1</sup> / <sub>8</sub>	22 <sup>9</sup> / <sub>32</sub>	18	1/4	26	184T	D4
24	24 <sup>3</sup> / <sub>16</sub>	27 <sup>7</sup> / <sub>8</sub>	29 <sup>3</sup> / <sub>8</sub>	23	1/4	36	184T	D7
28	28 <sup>1</sup> / <sub>4</sub>	31 <sup>5</sup> / <sub>8</sub>	33 <sup>3</sup> / <sub>8</sub>	23	1/4	36	215T	D5
32	32 <sup>1</sup> / <sub>4</sub>	35 <sup>3</sup> / <sub>4</sub>	37 <sup>1</sup> / <sub>2</sub>	28	1/4	39	256T	D5
36	36 <sup>1</sup> / <sub>4</sub>	39 <sup>3</sup> / <sub>4</sub>	41 <sup>1</sup> / <sub>2</sub>	28	1/4	44	256T	D4
40	40 <sup>3</sup> / <sub>8</sub>	43 <sup>3</sup> / <sub>4</sub>	45 <sup>1</sup> / <sub>2</sub>	34	1/4	48	286T	D6
44	44 <sup>3</sup> / <sub>8</sub>	47 <sup>3</sup> / <sub>4</sub>	49 <sup>1</sup> / <sub>2</sub>	37	1/4	51	365T	D4
48	48 <sup>3</sup> / <sub>8</sub>	52 <sup>3</sup> / <sub>8</sub>	54 <sup>3</sup> / <sub>8</sub>	37	1/4	58	365T	D4
54	54 <sup>3</sup> / <sub>8</sub>	59	61 <sup>1</sup> / <sub>8</sub>	40	3/8	63	365T	D4
60	60 <sup>3</sup> / <sub>8</sub>	65	67 <sup>1</sup> / <sub>8</sub>	41	3/8	65	404T	D3

Dimensions are not to be used for construction.

### Model MDVH Direct Drive Marine Duty Vaneaxial

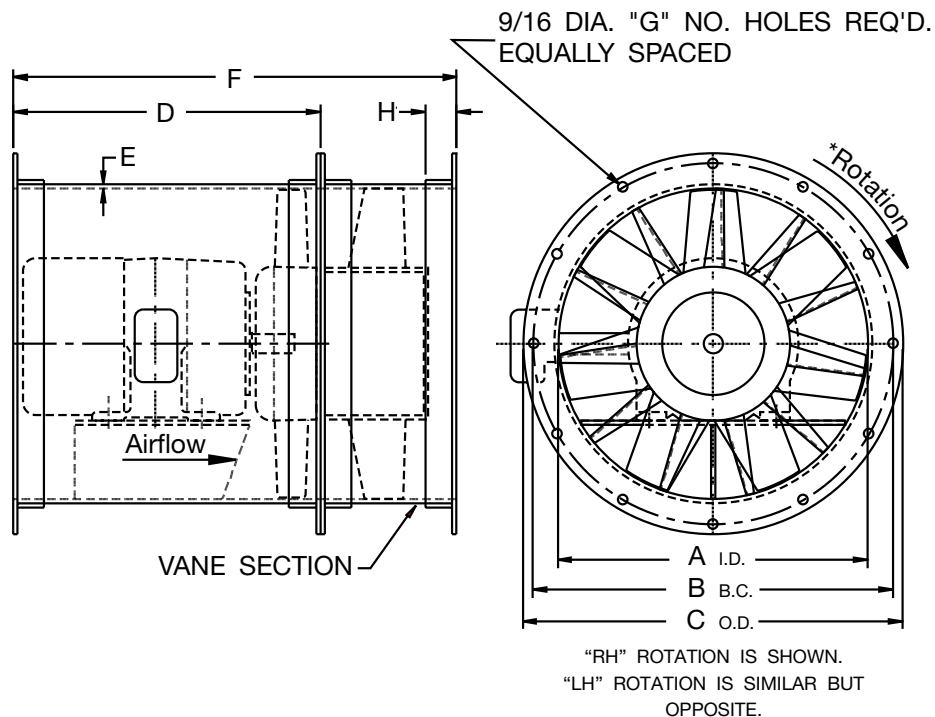

SIZE	A	B	C	D	E	F	G	H	MAX. MOTOR FRAME	HUB SIZE	*FAN ROTATION
12	12 <sup>5</sup> / <sub>32</sub>	14 <sup>1</sup> / <sub>8</sub>	15 <sup>3</sup> / <sub>4</sub>	20	1/4	34	12	1 <sup>1</sup> / <sub>2</sub>	145T	D6	RH
18	18 <sup>5</sup> / <sub>32</sub>	20 <sup>1</sup> / <sub>4</sub>	21 <sup>3</sup> / <sub>4</sub>	23	1/4	34	12	1 <sup>1</sup> / <sub>2</sub>	215T	D6	
21	21 <sup>3</sup> / <sub>16</sub>	23 <sup>1</sup> / <sub>4</sub>	24 <sup>3</sup> / <sub>4</sub>	26	1/4	43	12	1 <sup>1</sup> / <sub>2</sub>	256T	D5	
26	26 <sup>1</sup> / <sub>4</sub>	28 <sup>3</sup> / <sub>4</sub>	30 <sup>3</sup> / <sub>4</sub>	30	1/4	51	12	2	184T	D5	
29	29 <sup>1</sup> / <sub>4</sub>	31 <sup>3</sup> / <sub>4</sub>	33 <sup>3</sup> / <sub>4</sub>	31	1/4	54	12	2	215T	D5	
36	36 <sup>1</sup> / <sub>4</sub>	38 <sup>3</sup> / <sub>4</sub>	40 <sup>3</sup> / <sub>4</sub>	36	1/4	65	16	2	286T	D6	
42	42 <sup>3</sup> / <sub>8</sub>	44 <sup>3</sup> / <sub>4</sub>	46 <sup>3</sup> / <sub>4</sub>	37	1/4	69	16	2	364T	D6	
48	48 <sup>3</sup> / <sub>8</sub>	51 <sup>1</sup> / <sub>4</sub>	54	40	1/4	79	16	2 <sup>1</sup> / <sub>2</sub>	405T	D5	
54	54 <sup>1</sup> / <sub>2</sub>	57 <sup>3</sup> / <sub>4</sub>	60 <sup>3</sup> / <sub>8</sub>	53	3/8	85	16	2 <sup>1</sup> / <sub>2</sub>	447T	T	LH
60	60 <sup>1</sup> / <sub>2</sub>	63 <sup>3</sup> / <sub>4</sub>	66 <sup>3</sup> / <sub>8</sub>	53	3/8	90	16	2 <sup>1</sup> / <sub>2</sub>	444T	T	

Dimensions are not to be used for construction.

## Model MDTM, Arrg. 4, Direct Drive Tubeaxial Fans Model MDVM, Arrg. 4, Direct Drive Vaneaxial Fans

Fans, where indicated on drawings and schedules, shall be Model MDTM or Model MDVM, Arrangement 4, direct drive as manufactured by Aerovent, Minneapolis, Minnesota, and shall be of the size and capacity as indicated in the fan schedule. Model MDTM tubeaxial and Model MDVM vaneaxial fans shall be tested and rated in accordance with industry test codes and shall be guaranteed by the manufacturer to deliver at the rated published performance levels. In addition, each unit shall be factory run tested prior to shipment.

**CONSTRUCTION** — Fan casings shall be continuously welded 1/4" steel for sizes 12" through 48" diameter and 3/8" steel for sizes 54" and 60" diameter. Inlet and outlet flanges shall be of welded angle ring construction on fan casings through 16" diameter and shall be integrally rolled from the fan casing on sizes 18" through 60" diameter. Flanges are designed to ensure housing concentricity, housing strength, and permit duct mounting. The motor support base shall be fabricated of minimum 1/4" thick steel plate and shall be welded into the inlet end of the fan casing.

Fan casings shall be fitted with mounting legs for horizontal floor support, horizontal clips for ceiling suspension, vertical clips for floor or ceiling suspension, or flange mounted for direct duct connection as shown on drawings. Fan mounting supports shall be fabricated from hot rolled steel and shall be suitably braced to ensure stability and rigidity.

**GUIDE VANES** — A removable fan discharge guide vane section shall be furnished on Model MDVM vaneaxial fans. The guide vane section shall be designed to provide for maximum efficiency and straightening of the airflow. A quantity of eleven (11) accurately die-formed stationary guide vanes of 12-gauge hot rolled steel in sizes through 36" diameter and 7-gauge hot rolled steel in sizes 40" through 60" diameter shall be welded inside the guide vane section downstream of the propeller to insure optimum fan performance.

**PROPELLERS** — Propellers shall be one-piece cast aluminum with fixed-pitch blades and attached to the motor shaft with a split taper lock bushing. Propellers shall be statically and dynamically balanced to ensure quiet operation.

**MOTORS** — Direct drive fan motors shall be NEMA Design B, standard industrial, continuous duty, ball bearing, variable torque and shall be provided with the enclosure type, voltage, phase and hertz as listed in the fan schedule. If motors have regreasable bearings, external grease fittings with extended grease leads shall be supplied for lubrication of the motor bearings. Direct drive fans shall have the motor wiring extended through liquid-tight conduit to the outside of the housing for easy connection.

**BALANCING** — The propeller assembly shall be statically and dynamically balanced in accordance with ANSI/AMCA 204-96 "Balance Quality and Vibration Levels for Fans" to Fan Application Category BV-3, Balance Quality Grade G6.3. In addition, direct drive fan propellers shall be balanced on the motor shaft after final assembly in the fan casing, in the manufacturing facility, to the following peak velocity values, filter-in, at the fan test speed:

Fan Application Category	Rigidly Mounted (in./s)	Flexibly Mounted (in./s)
BV-3	0.15	0.20

**FINISH** — The unit, after fabrication, shall be cleaned and chemically pretreated by a phosphatizing process and shall be painted inside and outside with an air dry enamel. The fan shall be coated with the following optional finish:

- |                       |                |                 |                  |
|-----------------------|----------------|-----------------|------------------|
| • Hot Dip Galvanizing | • Plasite 3070 | • Plasite 7122L | • Carbocoat 30   |
| • Plasite 4310        | • Plasite 3055 | • Farboil       | • Heresite VR506 |

**SOUND POWER LEVELS** — Sound power level of fan(s) shall not exceed:  
Octave Band-CPS (Sound Power 10<sup>-12</sup>).

63	125	250	500	1000	2000	4000	8000

**ACCESSORIES** — The unit(s) shall be furnished complete with:

- |   |                     |
|---|---------------------|
| • Bolted Inspection Door                            | • OSHA Inlet Guard  |
| • Propeller Access Section                          | • OSHA Outlet Guard |
| • Support Legs                                      | • Inlet Bell        |
| • Horizontal Ceiling Clips                          | • Silencer – Inlet  |
| • Vertical Mounting Clips                           | • Silencer – Outlet |
| • Floor Mounted Vibration Isolators [RIS][Spring]   | • Inlet Vane Damper |
| • Ceiling Mounted Vibration Isolators [RIS][Spring] | • Cone – Inlet      |
| • Companion Flanges                                 | • Cone – Outlet     |

## Model MDVH, Arrg. 4, Direct Drive Vaneaxial Fans

Fans, where indicated on drawings and schedules, shall be Model MDVH, Arrangement 4, direct drive as manufactured by Aerovent, Minneapolis, Minnesota, and shall be of the size and capacity as indicated in the fan schedule. Model MDVH vaneaxial fans shall be tested and rated in accordance with industry test codes and shall be guaranteed by the manufacturer to deliver at the rated published performance levels. In addition, each unit shall be factory run tested prior to shipment.

**CONSTRUCTION** — Fan casings shall be continuously welded 1/4" steel for sizes 12" through 48" diameter and 3/8" steel for sizes 54" and 60" diameter. Inlet and outlet flanges shall be of welded angle ring construction on fan casings through 60" diameter and are designed to ensure housing concentricity, housing strength, and permit duct mounting. The motor support base shall be fabricated of minimum 1/4" thick steel plate and shall be welded into the inlet end of the fan casing.

Fan casings shall be fitted with mounting legs for horizontal floor support, horizontal clips for ceiling suspension, vertical clips for floor or ceiling suspension, or flange mounted for direct duct connection as shown on drawings. Fan mounting supports shall be fabricated from hot rolled steel and shall be suitably braced to ensure stability and rigidity.

A removable fan discharge guide vane section shall be furnished and shall be designed to provide for maximum efficiency and straightening of the airflow. A quantity of eleven (11) accurately die-formed stationary guide vanes of 12-gauge hot rolled steel in sizes through 36" diameter and 7-gauge hot rolled steel in sizes 42" through 60" diameter shall be welded inside the guide vane section downstream of the propeller to insure optimum fan performance.

**PROPELLERS** — Propellers shall be one-piece cast aluminum with fixed-pitch blades and attached to the motor shaft with a split taper lock bushing. Propellers shall be statically and dynamically balanced to ensure quiet operation.

**MOTORS** — Direct drive fan motors shall be NEMA Design B, standard industrial, continuous duty, ball bearing, variable torque and shall be provided with the enclosure type, voltage, phase and hertz as listed in the fan schedule. If motors have regreasable bearings, external grease fittings with extended grease leads shall be supplied for lubrication of the motor bearings. Direct drive fans shall have the motor wiring extended through liquid-tight conduit to the outside of the housing for easy connection.

**BALANCING** — The propeller assembly shall be statically and dynamically balanced in accordance with ANSI/AMCA 204-96 "Balance Quality and Vibration Levels for Fans" to Fan Application Category BV-3, Balance Quality Grade G6.3. In addition, direct drive fan propellers shall be balanced on the motor shaft after final assembly in the fan casing, in the manufacturing facility, to the following peak velocity values, filter-in, at the fan test speed:

Fan Application Category	Rigidly Mounted (in./s)	Flexibly Mounted (in./s)
BV-3	0.15	0.20

**FINISH** — The unit, after fabrication, shall be cleaned and chemically pretreated by a phosphatizing process and shall be painted inside and outside with an air dry enamel. The fan shall be coated with the following optional finish:

- |                       |                |                 |                  |
|-----------------------|----------------|-----------------|------------------|
| • Hot Dip Galvanizing | • Plasite 3070 | • Plasite 7122L | • Carbocoat 30   |
| • Plasite 4310        | • Plasite 3055 | • Farboil       | • Heresite VR506 |

**SOUND POWER LEVELS** — Sound power level of fan(s) shall not exceed:  
Octave Band-CPS (Sound Power 10<sup>-12</sup>).

63	125	250	500	1000	2000	4000	8000

**ACCESSORIES** — The fan(s) shall be furnished complete with:

- |  |  |
|--|--|
| <ul style="list-style-type: none"> <li>• Bolted Inspection Door</li> <li>• Propeller Access Section</li> <li>• Support Legs</li> <li>• Horizontal Ceiling Clips</li> <li>• Vertical Mounting Clips</li> <li>• Floor Mounted Vibration Isolators [RIS][Spring]</li> <li>• Ceiling Mounted Vibration Isolators [RIS][Spring]</li> <li>• Companion Flanges</li> </ul> | <ul style="list-style-type: none"> <li>• OSHA Inlet Guard</li> <li>• OSHA Outlet Guard</li> <li>• Inlet Bell</li> <li>• Silencer – Inlet</li> <li>• Silencer – Outlet</li> <li>• Inlet Vane Damper</li> <li>• Cone – Inlet</li> <li>• Cone – Outlet</li> </ul> |
|--|--|

---

**PROPELLER FANS | TUBEAXIAL & VANEAXIAL FANS | CENTRIFUGAL FANS & BLOWERS | ROOF VENTILATORS  
INDUSTRIAL AIR HANDLERS | AIR MAKE-UP | FIBERGLASS FANS | CUSTOM FANS**



**AEROVENT**  
A Twin City Fan Company

**AEROVENT**   
INDUSTRIAL VENTILATION SYSTEMS

**[WWW.AEROVENT.COM](http://WWW.AEROVENT.COM)**

---

**5959 Trenton Lane N | Minneapolis, MN 55442 | Phone: 763-551-7500 | Fax: 763-551-7501**