

AEROVENT

INDUSTRIAL VENTILATION SYSTEMS

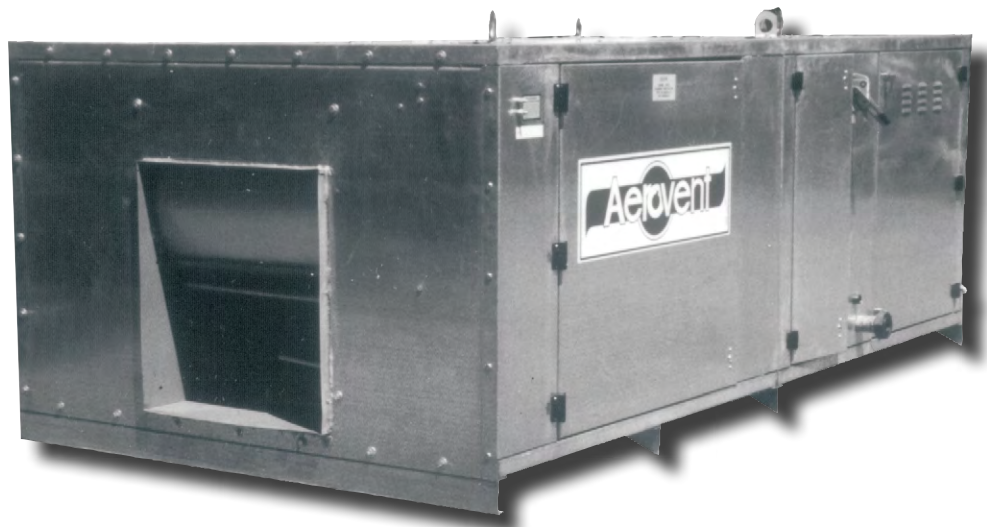

DIRECT-FIRED GAS AIR MAKE-UP UNITS

Model FCBT / BIBT

Built to ANSI Z83.4 & Z83.18 Standards

ETL Approved

Introduction

What is make-up air?

Make-up air is outside air tempered and introduced into a building to eliminate negative pressure and provide a positive operating pressure within a facility.

Why do you need make-up air?

Fans and blowers used in spray booths, hoods, ovens, dust collectors, ventilators, and other plant equipment exhaust air to the outside. Without a controlled introduction of “make-up” air an air-starved environment will result.

When do you know you need make-up air?

Make-up air is required when:

- Gravity stacks from unit heaters and processes backvent.
- Exhaust systems do not perform at rated volume leading to poor control of contaminants.
- The perimeter of the building is cold due to a high infiltration rate.
- There are several indrafts at exterior doors, windows, and building openings.
- Exterior doors are hard to open.
- Heating systems are not able to maintain uniform comfort conditions throughout the building. The outer core area is cold due to infiltration while the center core is overheated.

How much does make-up air cost?

Make-up air doesn't cost money. It actually saves money by:

- Extending the life of heat exchangers on combustion equipment.
- Providing more uniform temperatures throughout the building, reducing overheated areas and cold drafty areas.
- Allowing exhaust systems to operate at designed capacity, reducing the need for additional equipment.

- Minimizing the damage to materials from contaminants which may exist in the the local atmosphere.
- Reducing employee turnover and absenteeism because of better health conditions and plant cleanliness.
- Improving products with fewer rejects because furnaces operate at designed conditions.

How much make-up air do you need?

The recommended procedure to determine the amount of make-up air needed is to total the CFM capacity of all the exhaust fans and blowers in the plant and add 10% to create a positive pressure situation.

If the data is not available, the following equations can be used as a means of determining how much make-up air is required.

Paint Spray Booth: 125 to 175 CFM per square foot of face opening.

Oven Exhaust: One air change per minute of oven volume in cubic feet.

Fume Exhaust: CFM = area of discharge pipe in square feet x velocity (3,000 fpm average).

Roof Ventilator: CFM = area of discharge pipe in square feet x velocity (3,000 fpm average).

Dust Collector: Area of discharge pipe in square feet x velocity (4,000 fpm average).

Canopy Hoods: 100 to 300 CFM per square foot of hood open area.

Combustion Air For Furnaces: CFM = fuel consumed in Btu per hour divided by 6,000.

Drying, Baking, or Curing Ovens: 100 CFM per square foot of both cross sections.

Pickling or Cleaning Tanks: 150 CFM per square foot of door opening or 200 CFM per square foot of hood face opening.

Contents

Introduction	2	Sequence of Operation – Gas Burner	8
Application Considerations	3	Typical Specifications	9
Construction Features	4	Performance Data – Forward Curved	10
Accessories	5	Performance Data – Backward Inclined	11
Standard Temperature Controls	6	Dimensional Data	12-23
Control Panel	7	Pressure Drop Curves for Accessories	24-27
Pipetrain	7		

©2004 Aerovent, Twin City Fan Companies, Ltd.
Catalog illustrations cover the general appearance of products at the time of publication and we reserve the right to make changes in design and construction at any time without notice.

Application Considerations

Air Balance

Exhaust fans cannot work properly without an adequate supply of air. If provision for air supply is not made, the vacuum created reduces the effectiveness of mechanical ventilation. Negative pressure also causes excessive infiltration, making it difficult to heat properly. These conditions can be corrected by replacing the exhausted air with clean, fresh, pretreated air. The primary purpose of make-up air is to temper outside air and supply it in sufficient quantities to bring about the condition of balanced ventilation.

Depending upon the quantity of make-up air in relation to the exhaust, the heating system will shut down during the working day allowing the make-up air system to handle the entire load. The heating system then functions only to maintain satisfactory temperatures at nighttime and other plant shutdown periods.

When you add an air make-up system to an existing plant it is necessary to make a detailed analysis of the overall situation in order to determine what the relationship might be between the heat added by make-up air and that supplied from the plant heating system. Where exhaust systems already exist, the installation of make-up air usually will not increase the heating load and can bring about a reduction of overall heating costs. This may be understood by considering that infiltrated air, warmed at least partially by the plant heating system, is ultimately mixed with room air and exhausted through the ventilating fans. Infiltration of unheated air results in a decline of heating efficiency. Most heating systems are not adequately rated to cope with infiltration when appreciable negative pressures exist. Air make-up units provide a systematic method of heating entering air and supplying it in controlled quantity. With the proper balance of supply and exhaust, infiltration is eliminated and negative pressures are equalized. By properly tempering supply air, the heating system is relieved of this abnormal load. The results are uniform space heating, effective ventilation, and improved comfort.

Heating

Experience with fresh air heating systems has shown that it is practical and economically sound to heat industrial plants and even warehouses with fresh air. The question of whether to use 100% fresh air or recirculate some portion is debatable, and engineers are using both methods in their applications.

When direct-fired systems were first used some authorities felt that positive exhaust was necessary to assure a balance and prevent the possibility of products of combustion buildup. It is now generally recognized that air can be supplied into most buildings having no mechanical exhaust and in quantities sufficient to heat them without building up a positive pressure of more than a few hundredths of an inch water gauge. It is the reverse of infiltration and this principle can be used to design fresh air plant heating.

The standard air make-up unit is used for industrial space heating with 100% outside air or with a fixed percentage of recirculation, and in some designs with a combination of these. Your Aerovent representative can assist you in determining application requirements for general air make-up and for fresh air heating. They can supply detailed information as it may apply to specific conditions.

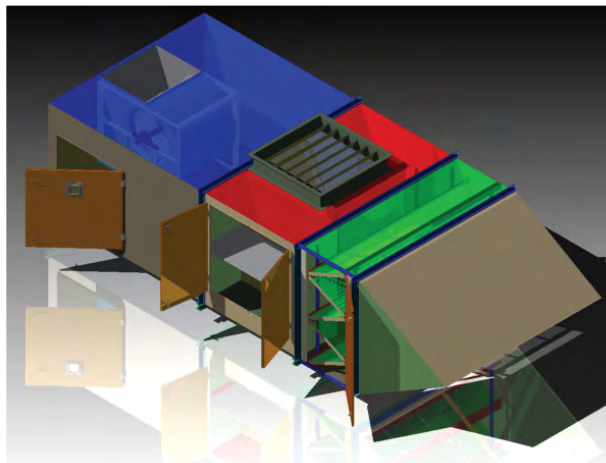

Construction Features

The BT series direct-fired gas air make-up unit is a complete air supply system in a self-contained package with fan, burner, and controls. The unit is ready for connection to the gas line and power source. These systems are for use in industrial or commercial applications where supplying tempered outside air is required.

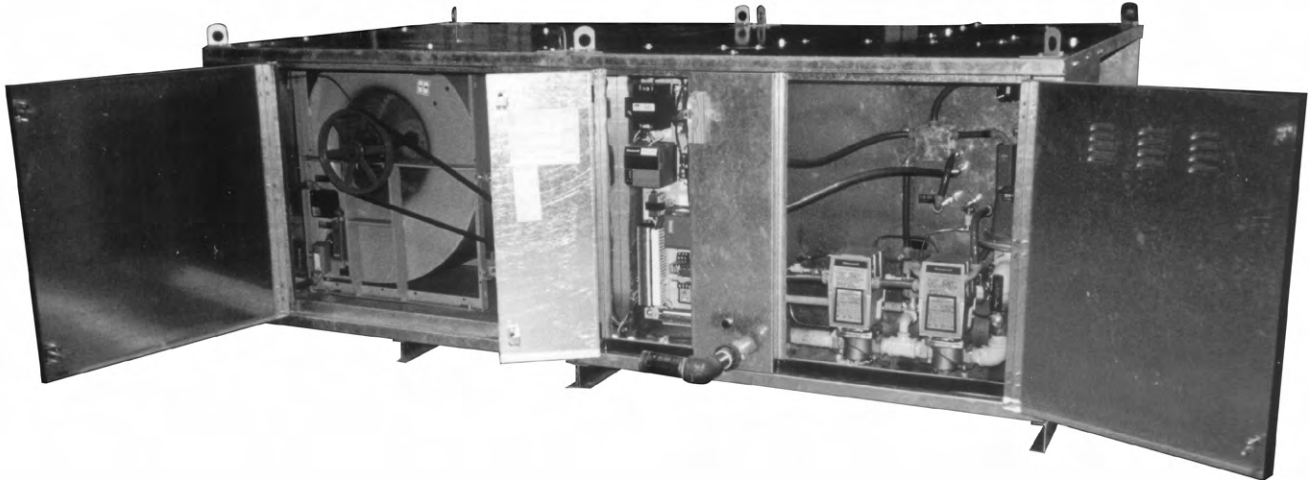

Standard Features

- Heavy duty forward curved or backward inclined DWDI centrifugal blower with pillow block bearings
- ANSI and FM approved gas manifold design
- Heavy duty 14 gauge steel housing
- Enamel paint
- Large access door for internal accessibility
- Lifting eyes for ease of unit installation
- Venturi monitored airflow supervision
- 0 to 92 degree temperature rise
- 120 volt fused control circuit with 230/460 to 120 volt control transformer
- Number-coded wires and terminal strips
- Dual fuel burner (Maxon)
- Factory assembled and tested
- Weatherproof control enclosure
- Remote operating station
- Unit support/mounting channels
- Maxitrol Series 14 temperature control
- Honeywell series 7800 flame safeguard protection
- Flame rod
- Safety shutoff valves
- Discharge temperature sensor
- Drives rated for 150% of motor nameplate rating
- High temperature limit
- Single point gas and electrical connections
- Non-recycle system with low fire start protection with main flame supervision
- 25:1 temperature control modulation
- Pilot gas pressure regulator
- High and low gas pressure switch

Accessories

80/20 Recirculating

The 80/20 recirculating system allows 80% recirculation and is designed to insure that a minimum of 20% of the designed performance is outside air. Recirculated air is not allowed to flow across the burner. Manual setpoint is standard. Room pressure control available as an option.

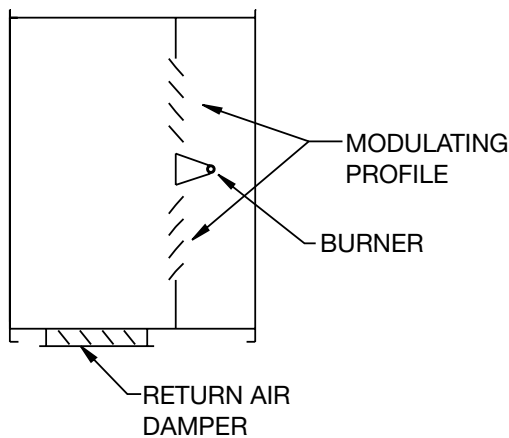

V-Bank Filter Section

The standard filter is a 2" Farr 30/30 disposable type with washable as an option.

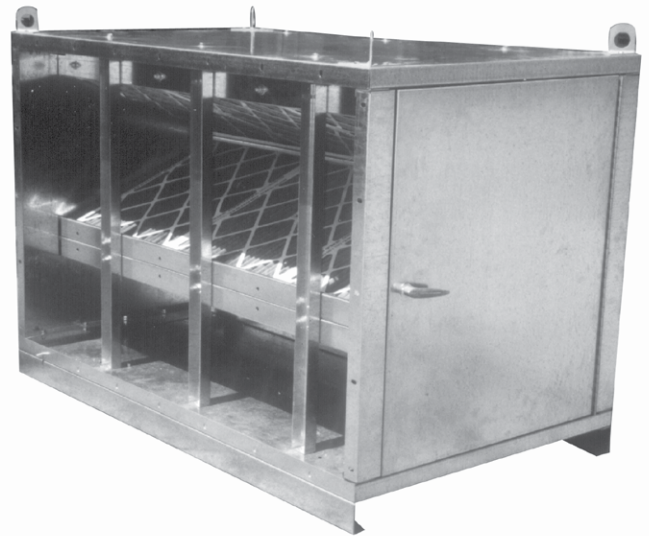

Additional Options

- V-bank filter section
- Intake hood with bird screen
- 90 degree discharge elbow
- Roof curb
- Curb mount construction
- Inlet bird screen
- Modulating room temperature control (Maxitrol Series 44)
- IRI pipe train manifolds
- Directional discharge grille, single and double deflection
- Circuit analyzer
- Insulated construction
- Vertical support stand
- Two speed operation
- UV flame scanner
- Mild weather thermostat
- Service platform
- Main gas regulator
- Vibration isolators (unit mount)
- Tamper proof remote station
- Reset module
- Disconnect switch
- OSHA Belt guard
- Motor operated damper (inlet or discharge)
- Freeze protection thermostat
- Door switch interlock
- Painted unit and accessories
- Extended grease lines

Standard Temperature Controls

Two standard systems for temperature control are available offering a choice of functions for the regulation of air temperature. The outlet temperature control (OTC) system senses only the discharge air temperature at the unit. The sensing device is located in the airstream. It averages the temperature and sends a signal to the servomechanism in the modulating regulator. The regulator in turn modulates the gas pressure in the burner manifold, and the gas flow is varied to maintain the air temperature constant at the sensor. The OTC system is used where the volume of air supplied is relatively small compared to the volume of the building, which usually means that it is not intended for the air make-up unit to pick up an appreciable part of the building heating.

In most installations, room temperature control is desirable. Two controllers are available for this operation. The simplest and least expensive control is a thermostat added to the OTC system (OTC-RO) and located to sense the room temperature. The contacts close on a call for heat and cause an increase in the discharge air temperature. The air make-up unit delivers air at the higher temperature until the room thermostat is satisfied; full control is then returned to the discharge sensor. The limited amount of temperature increase eliminates excessive discharge air temperature. The temperature setting is usually 5° below the outlet temperature set point.

The modulating room temperature control (MRTC) is slightly more sophisticated. Instead of a thermostat, a thermistor is used to sense the room temperature. The signal actuates the modulating regulator



Tamper-proof control system

to provide an incremental increase or decrease of the discharge temperature, providing closer control and preventing an abrupt change in the temperature of the air at the outlet of the unit or outlets of a distribution system. In the room temperature control system the discharge air temperature sensor performs a limiting function so that the discharge air cannot exceed a reasonable temperature. The discharge air temperature can be set to suit the individual requirements at the time of installation.

The air temperature controllers are combined with the operation selector switch and indicator lights—all mounted in a remote operating station. The OTC unit can be mounted in any convenient location and contains a summer-off-winter selector switch and indicator lamps showing that power is on, the fan is running, and there is a flame on the burner. There is also a knob for setting the discharge temperature of the air make-up unit.

The OTC-RO control station contains all of these controls and indicators in addition to a room temperature thermostat. The MRTC remote operating station has a thermistor on top instead of the on-off thermostat. The OTC-RO or MRTC remote operating stations should be mounted in a location where the desired room temperature is best sensed. This will be a matter of judgment, made at the time of installation.

The circuit design can include an optional mild weather thermostat. This thermostat senses the outside temperature and, at a predetermined setting, will cause the burner to be shut off completely while allowing the fan to run. This makes it possible to have year-round operation with the selector switch set to the winter position and the mild weather thermostat set to a desirable “heat off” temperature (65°F). When the outside temperature is above 65° the heat will be off. When it is below 65° the burner will be in operation and the temperature regulated according to the modulating control.



Outlet Temperature Control (OTC)



Modulating Room Temperature Control (MRTC)

Control Panel

The main control panel is designed with the service technician in mind. The panel is licensed to carry the UL label under the 508 listing. The panel meets all standards of the National Electric Code and includes as standard:

- Step-down control transformer
- Motor starter with overloads
- Ignition transformer
- Honeywell 7800 series primary flame safe-guard system
- Maxitrol temperature controller
- Purge and reset timers

The incorporation of the Honeywell series 7800 flame relay offers the customer the following options:

- Remote relay reset (reset lockout from remote panel)
- Fault history (readout of six most recent faults from LED readout for troubleshooting flame failures)

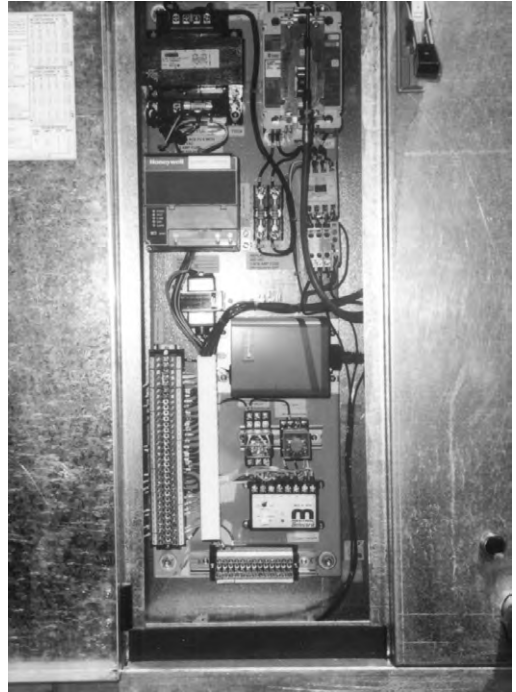

Pipetrain

Liquid-tight conduit is used for all interconnecting wiring. Piping is in accordance with ANSI standard along with IRI and FM.

- Motorized safety shutoff valve
- Blocking valve
- Pilot solenoid
- High/Low gas pressure switch
- Pilot regulator
- Manual pilot shutoff valve
- Maxitrol MR 212 modulating valve
- Vent valve as required by IRI
- Adjustable pilot orifice

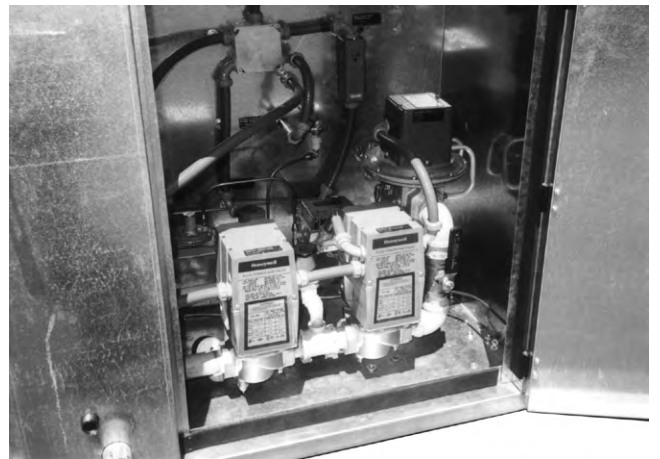

Sequence of Operation – Gas Burner

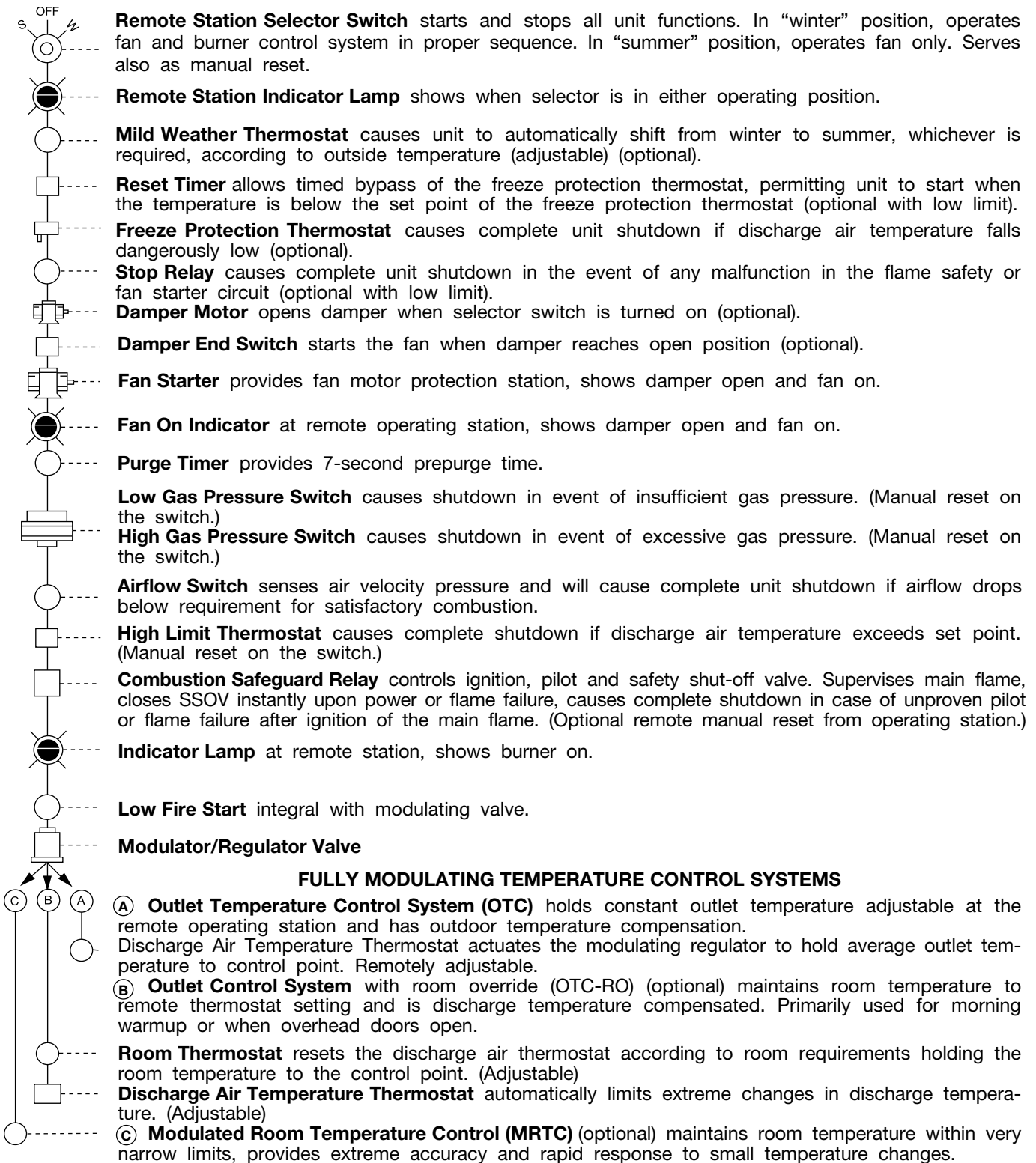

Typical Specifications

Models FCBT forward curved and Models BIBT backward inclined direct-fired gas centrifugal DW air make-up units shall be manufactured by Aerovent, Minneapolis, Minnesota and shall be of the size and capacity as indicated on drawings and schedules.

WHEEL — Wheels shall be double width with forward curved blades or backward inclined blades. The forward curved wheels feature die-formed blades assembled in heavy end rings and center plate. Wheels shall be statically and dynamically balanced and furnished with straight bore hubs.

HOUSING — Housings shall be of 14 gauge steel, of modular construction where sections are mechanically fastened. Housings shall be equipped with a visual burner inspection port, access door, lifting eyes, and unit support frame for mounting.

GAS PIPETRAIN — Pipetrain shall consist of SSOV valve, pilot valve, vent valve (IRI only), blocking valve, high-low gas pressure switches with manual resets, heavy duty plug cocks, pressure gauge and modulating regulator out of the airstream. Piping shall conform to FM or IRI standards. Please specify when ordering.

CONTROL CABINET — A control cabinet shall house the fan motor magnetic starter with manual reset over-load relays, control transformer, Honeywell solid-state flame sensing relay, non-recycle timer, fuse and terminal strips. Unit shall include a remote control station with summer-winter-off selection switch, power on, fan on, burner on lights, and discharge temperature selector. The temperature control system shall be of solid-state design manufactured by the Maxitrol Company to modulate the burner in accordance with the remote control station setting. All controls on the unit are to be wired to the respective points in the cabinet with liquid-tight conduit and in accordance with the National Electric Code. The unit shall also include high temperature limit, airflow switch, and positive low fire start.

FLAME DETECTOR — A flame rod flame detector shall be incorporated into the unit to supervise both the pilot and main burner flame.

BURNER — The burner is a Maxon with 25:1 turndown ratio. The manifold body is heavy duty cast iron, fully treated for rust resistance. The mixing plates are type 430 stainless steel.

UNITS SHALL COME COMPLETE WITH:

- V-Bank Filter Cabinet
- Inlet Hood with Vanes
- Inlet Hood less Vanes
- 90 Degree Discharge Elbow
- Filtered Inlet Hood
- Directional Discharge Grille
- Vibration Isolators
- Tamperproof Control Station
- Push-to-Test Lights
- Curb Mounting
- Roof Curb
- Mild Weather Control
- Freeze Protection Thermostat
- Inlet Bird Screen
- Circuit Analyzer
- OSHA Belt Guard
- Reset Module
- Service Platform
- Insulated Construction
- UV Flame Detection
- Digital Temperature Controls
- Door Switch Interlock
- Vertical Support Stand
- Two Speed Operation
- Main Gas Regulator
- Disconnect Switch
- Extended Grease Lines
- Modulating Room Temperature Controls

TESTING — Unit(s) shall be guaranteed by the manufacturer to deliver at the rated performance levels. Unit(s) shall be completely packaged and test fired at the factory before shipment.



Performance Data

Model FCBT Forward Curved Centrifugal DW Direct-Fired Gas Air Make-Up Units

Catalog Numbering System

Assign catalog number by using the numbering system outlined in the example at right. Fan type, fan size, RPM, and HP are found in the rating tables.

FCBT - 118 - 943 - 7¹/₂

Forward Curved
DW Air Make-Up

Fan Size

Fan RPM

Motor HP

Definitions

Btu/Hr is sensible heat release. To determine cfm gas input, divide Btu by the net heat value of the fuel.

CFM is net volume at discharge at 70°F.

External Static Pressure is pressure available for addition of ducts.

AMU MODEL	FAN MODEL	CFM	OUT-LET VE-LOC-ITY	BTU/HR	ISP	EXTERNAL STATIC PRESSURE															
						1/4"		1/2"H		3/4"		1"		1 1/4"		1 1/2"		1 3/4"		2"	
						RPM	BHP	RPM	BHP	RPM	BHP	RPM	BHP	RPM	BHP	RPM	BHP	RPM	BHP	RPM	BHP
FCBT 110	VFC 16	4000	1446		0.875	666	1.25	740	1.53	808	1.83	869	2.12	928	2.43	984	2.73	1038	3.04	1089	3.35
FCBT 115	VFC 16	5000	1807		0.875	665	1.62	735	1.94	800	2.26	862	2.61	920	2.96	975	3.32	1027	3.7	1076	4.07
FCBT 115	VFC 16	6000	2168		0.875	675	2.14	739	2.47	799	2.81	858	3.19	914	3.57	967	3.96	1019	4.37	1069	4.8
FCBT 118	VFC 18	7500	2152		0.875	622	2.62	672	2.97	721	3.36	767	3.74	812	4.15	857	4.59	902	5.05	948	5.56
FCBT 120	VFC 20	10000	2283		0.875	571	3.72	615	4.19	657	4.67	698	5.18	737	5.71	774	6.23	812	6.81	849	7.39
FCBT 122	VFC 22	12500	2271		0.875	510	4.65	549	5.22	587	5.84	623	6.46	658	7.12	692	7.8	725	8.49	759	9.26
FCBT 127	VFC 28	15000	1728		0.875	391	5.08	430	6.02	467	7.02	501	8.01	532	8.97	562	9.97	590	10.95	619	12.04
FCBT 127	VFC 28	17500	2016		0.875	400	6.49	435	7.44	469	8.47	502	9.57	534	10.73	564	11.89	592	13.02	619	14.18
FCBT 130A	VFC 28	20000	2304		0.875	412	8.27	445	9.27	476	10.32	507	11.49	536	12.63	566	13.95	594	15.24	621	16.55
FCBT 130A	VFC 28	22500	2592		0.875	427	10.41	457	11.51	487	12.64	516	13.86	543	15.04	570	16.32	597	17.7	623	19.09
FCBT 130B	VFC 32	25000	2290		0.875	365	9.52	391	10.63	417	11.88	442	13.18	467	14.66	491	16.2	514	17.74	537	19.35
FCBT 130B	VFC 32	30000	2749		0.875	391	13.86	415	15.13	438	16.43	460	17.76	482	19.23	503	20.69	524	22.27	545	23.99
FCBT 136	VFC 36	35000	2547		0.875	336	14.72	358	16.18	380	17.86	401	19.57	421	21.3	441	23.19	461	25.28	480	27.38
FCBT 136	VFC 36	40000	2910		0.875	355	19.5	376	21.27	396	22.97	416	24.87	435	26.87	453	28.64	471	30.65	489	32.8
FCBT 140	VFC 40	50000	2894		0.875	322	24.87	341	27.15	358	29.07	376	31.45	393	33.82	409	36.11	425	38.58	441	41.21
FCBT 222	VFC-2 22	25000	2271		0.875	536	10.02	577	11.26	616	12.53	654	13.88	691	15.32	726	16.73	761	18.24	796	19.84
FCBT 222	VFC-2 22	30000	2726		0.875	569	14.32	607	15.8	643	17.26	678	18.8	711	20.29	744	21.9	776	23.54	806	25.13
FCBT 225	VFC-2 25	35000	2534		0.875	491	15.33	527	17.14	560	18.87	592	20.66	623	22.51	653	24.42	682	26.37	711	28.46
FCBT 227	VFC-2 28	40000	2304		0.875	432	17.7	467	19.91	500	22.21	532	24.66	563	27.19	594	29.95	624	32.81	653	35.73
FCBT 227	VFC-2 28	45000	2592		0.875	448	22.32	480	24.76	512	27.29	542	29.83	571	32.48	599	35.18	626	37.9	654	41.01
FCBT 230	VFC-2 28	50000	2880		0.875	467	27.72	497	30.62	525	33.19	554	35.96	582	33.77	608	41.49	634	44.44	660	47.59
FCBT 230	VFC-2 28	55000	3168		0.875	491	34.48	515	37.03	542	40.14	568	43.11	594	46.03	620	49.07	645	52.16	669	55.26
FCBT 233	VFC-2 32	60000	2749		0.875	410	29.69	435	32.36	460	35.34	483	38.19	506	41.32	529	44.7	551	48.08	572	51.5
FCBT 233	VFC-2 32	65000	2978		0.875	425	35.28	450	38.57	473	41.47	495	44.39	517	47.64	538	50.86	559	54.33	580	58.03
FCBT 236	VFC-2 36	70000	2547		0.875	353	31.7	376	34.82	399	38.4	421	42.07	442	45.77	463	49.84	484	54.34		
FCBT 236	VFC-2 36	75000	2728		0.875	363	36.7	385	39.92	407	43.55	428	47.28	449	51.35	469	55.41	489	59.79		
FCBT 240	VFC-2 40	100000	2894		0.875	338	53.43	358	58.35	376	62.54	395	67.73	412	72.37	429	77.4	446	82.81		

Performance ratings of the base units include the effects of appurtenances in the airstream (i.e. burner section).

Performance ratings do not include the effects of optional accessories in the airstream (i.e. filter cabinet). See pages 24-27 for pressure losses.

Power rating (bhp) does not include drive losses.

Performance ratings are based on units with ducted discharge.

Performance Data

Model BIBT Backward Inclined Centrifugal DW Direct-Fired Gas Air Make-Up Units

Catalog Numbering System

Assign catalog number by using the numbering system outlined in the example at right. Fan type, fan size, RPM, and HP are found in the rating tables.

BIBT - 116 - 2179 - 5

Backward Inclined
DW Air Make-Up

Fan Size

Fan RPM

Motor HP

Definitions

Btu/Hr is sensible heat release. To determine cfm gas input, divide Btu by the net heat value of the fuel.

CFM is net volume at discharge at 70°F.

External Static Pressure is pressure available for addition of ducts.

AMU MODEL	FAN MODEL	CFM	OUT-LET VE-LOC-ITY	BTU/HR	ISP	EXTERNAL STATIC PRESSURE															
						1/4"		1/2"H		3/4"		1"		1 1/4"		1 1/2"		1 3/4"		2"	
						RPM	BHP	RPM	BHP	RPM	BHP	RPM	BHP	RPM	BHP	RPM	BHP	RPM	BHP	RPM	BHP
BIBT 116	VBC 16	4000	1446		0.875	1247	1.12	1319	1.31	1387	1.5	1453	1.7	1514	1.9	1574	2.1	1632	2.31	1691	2.52
BIBT 116	VBC 16	5000	1807		0.875	1399	1.61	1464	1.83	1527	2.06	1586	2.29	1643	2.53	1699	2.77	1753	3.02	1805	3.26
BIBT 116	VBC 16	6000	2168		0.875	1566	2.27	1624	2.52	1680	2.78	1735	3.05	1788	3.32	1839	3.59	1889	3.88	1937	4.16
BIBT 116	VBC 16	7500	2711		0.875	1836	3.86	1884	3.97	1932	4.27	1979	4.57	2025	4.89	2071	5.22	2115	5.54	2159	5.88
BIBT 122	VBC 22	10000	1817		0.875	1005	3.25	1051	3.69	1095	4.15	1137	4.61	1178	5.09	1217	5.57	1255	6.05	1292	6.55
BIBT 122	VBC 22	13000	2362		0.875	1190	5.45	1228	5.97	1266	6.52	1302	7.07	1338	7.64	1373	8.23	1408	8.84	1441	9.43
BIBT 125	VBC 25	15000	2143		0.875	1009	5.81	1040	6.34	1072	6.92	1104	7.53	1136	8.17	1167	8.82	1197	9.46	1227	10.12
BIBT 125	VBC 25	18000	2571		0.875	1157	8.77	1184	9.41	1211	10.05	1237	10.68	1264	11.37	1290	12.06	1317	12.8	1343	13.54
BIBT 128	VBC 28	19500	2247		0.875	917	7.82	944	8.51	972	9.26	999	10.02	1027	10.84	1054	11.67	1080	12.49	1106	13.34
BIBT 128	VBC 28	22000	2535		0.875	1004	10.27	1029	11.06	1053	11.82	1077	12.62	1102	13.48	1126	14.34	1151	15.26	1175	16.2
BIBT 132	VBC 32	25000	2290		0.875	830	10.28	854	11.75	878	12.09	902	13.07	926	14.1	950	15.16	973	16.22	996	17.3
BIBT 132	VBC 32	29500	2703		0.875	942	15.02	963	16.06	984	17.12	1004	18.15	1024	19.21	1045	20.37	1065	21.52	1086	22.76
BIBT 136	VBC 36	34000	2474		0.875	784	15.39	804	16.58	824	17.81	844	19.08	864	20.42	884	21.81	903	23.17	923	24.66
BIBT 136	VBC 36	40000	2910		0.875	892	22.59	910	24.05	927	25.44	944	26.85	961	28.28	978	29.74	995	31.26	1012	32.83
BIBT 140	VBC 40	50000	2894		0.875	797	28.2	813	30.03	828	31.74	844	33.59	859	35.35	874	37.16	889	39.03	904	40.96
BIBT 222	VBC-2 22	25000	2271		0.875	1216	10.79	1257	11.87	1298	13.02	1337	14.18			1413	16.61	1450	17.86	1485	19.1
BIBT 222	VBC-2 22	30000	2726		0.875			1424	17.37	1460	18.67	1494	19.94	1528	21.29	1562	22.69	1595	24.1	1627	25.51
BIBT 225	VBC-2 25	35000	2500		0.875	1189	17.69	1218	19.01	1246	20.31	1275	21.7	1303	23.11	1332	24.62	1361	26.19	1389	27.76
BIBT 228	VBC-2 28	40000	2304		0.875	981	17.79	1009	19.31	1037	20.89	1065	22.57	1093	24.31	1121	26.13	1149	28.01	1176	29.88
BIBT 228	VBC-2 28	45000	2592		0.875	1073	23.28	1098	24.95	1123	26.65	1148	28.4	1173	30.22	1198	32.12	1224	34.17	1248	36.11
BIBT 228	VBC-2 28	50000	2880		0.875	1167	29.87	1191	31.84	1214	33.73	1236	35.57	1259	37.52	1281	39.44	1304	41.52	1326	43.57
BIBT 228	VBC-2 28	55000	3168		0.875	1263	37.71	1285	39.89	1307	42.07	1328	44.16	1348	46.17	1369	48.3	1389	50.37		
BIBT 232	VBC-2 32	60000	2749		0.875	1003	33.65	1024	35.87	1046	38.21	1067	40.48	1088	42.82	1109	45.25	1130	47.77	1151	50.37
BIBT 232	VBC-2 32	65000	2978		0.875	1070	40.73	1091	43.33	1111	45.81	1130	48.18	1150	50.71	1169	53.17	1189	55.83		
BIBT 236	VBC-2 36	70000	2547		0.875	842	35.41	863	38.11	883	40.74	903	43.46	923	46.29	944	49.4	964	52.46	984	55.62
BIBT 236	VBC-2 36	75000	2728		0.875	889	41.62	909	44.56	928	47.38	947	50.25	965	53.05	984	56.12				
BIBT 240	VBC-2 40	100000	2894		0.875	837	60.67	854	64.64	870	68.39	886	72.17								

Performance ratings of the base units include the effects of appurtenances in the airstream (i.e. burner section).

Performance ratings do not include the effects of optional accessories in the airstream (i.e. filter cabinet).

See pages 24-27 for pressure losses.

Power rating (bhp) does not include drive losses.

Performance ratings are based on units with ducted discharge.



Single Fan Model FCBT – Size 110-122 Direct-Fired Gas Air Make-up Unit

Horizontal Configuration - 100% Outside Air

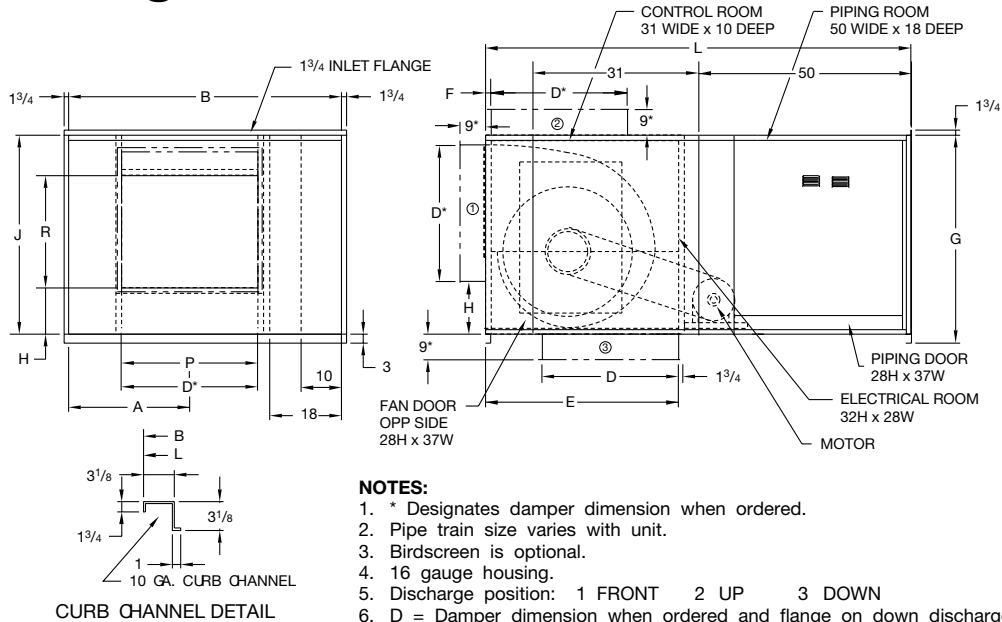

SIZE	A	B	D	E	F	G	H	J	L	P	R	APPROX. WTS. (LB)
FCBT-110	24.25	58.50	24.00	18.93	1.25	39.00	6.25	36.00	81.00	13.62	11.38	1,067
FCBT-115	24.25	58.50	24.00	25.81	1.25	39.00	8.62	36.00	81.00	18.62	15.88	1,148
FCBT-118	24.25	58.50	24.00	30.75	1.25	39.00	8.62	36.00	81.00	21.88	18.68	1,148
FCBT-120	36.75	73.50	30.00	37.31	1.25	51.00	11.25	48.00	108.00	22.75	24.75	1,595
FCBT-122	36.75	73.50	30.00	40.81	1.25	51.00	12.25	48.00	108.00	27.25	27.25	1,620

DIMENSIONS ARE NOT TO BE USED FOR CONSTRUCTION.

R27610A

Vertical Configuration - 100% Outside Air

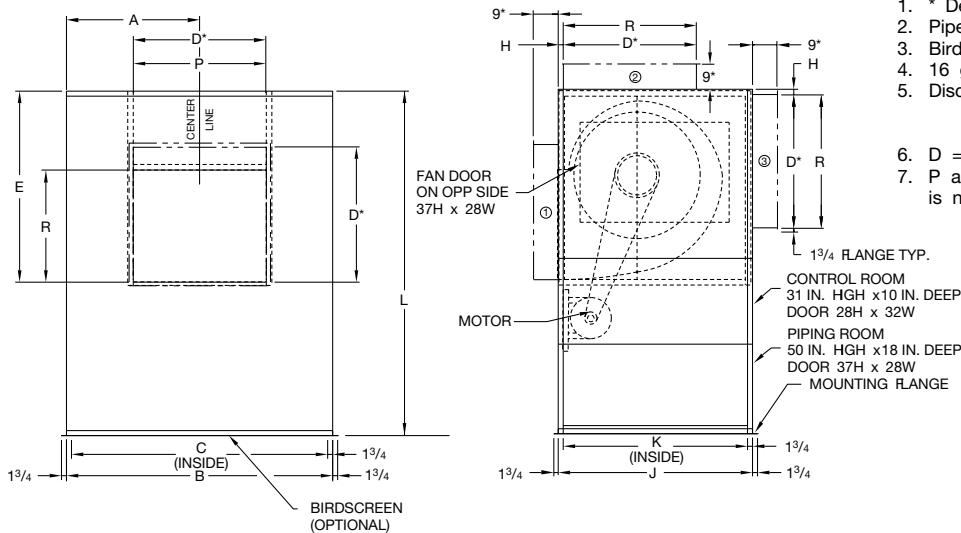

SIZE	A	B	C	D	E	F	G	H	J	K	L	P	R	APPROX. WTS. (LB)
FCBT-110	24.25	58.50	56.00	24.00	18.93	2.25	39.00	1.25	36.00	33.50	81.00	13.62	11.38	1,067
FCBT-115	24.25	58.50	56.00	24.00	25.81	2.25	39.00	1.25	36.00	33.50	81.00	18.62	15.88	1,148
FCBT-118	24.25	58.50	56.00	24.00	30.75	2.25	39.00	1.25	36.00	33.50	81.00	21.88	18.68	1,148
FCBT-120	36.75	73.50	71.00	30.00	37.31	3.25	51.00	1.25	48.00	45.50	108.00	22.75	24.75	1,595
FCBT-122	36.75	73.50	71.00	30.00	40.81	3.25	51.00	1.25	48.00	45.50	108.00	27.25	27.25	1,620

DIMENSIONS ARE NOT TO BE USED FOR CONSTRUCTION.

R27608

Single Fan Model FCBT – Size 110-122 Direct-Fired Gas Air Make-up Unit

Horizontal Configuration - 80/20 Recirculation

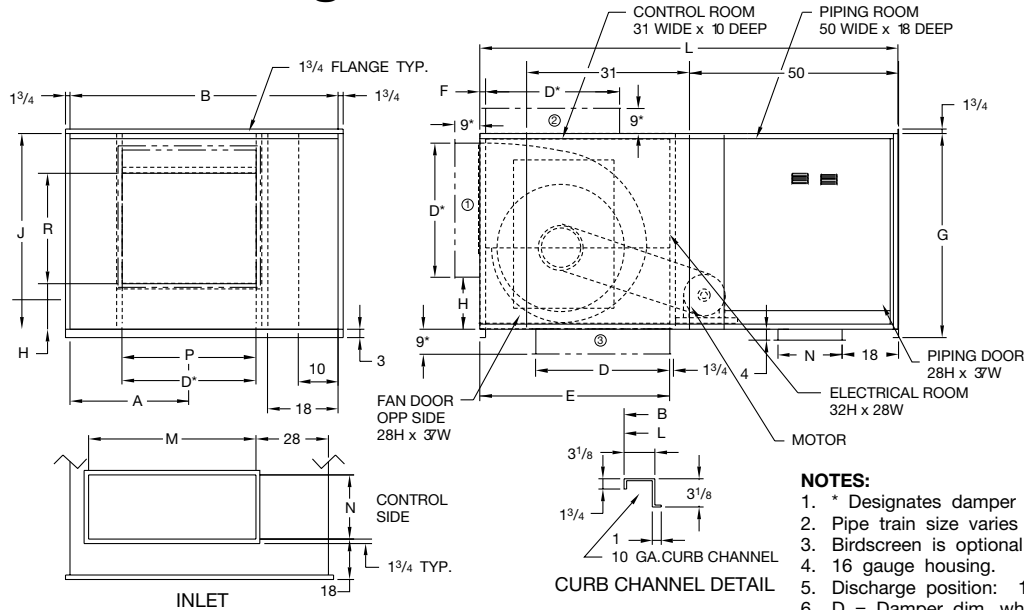

NOTES:

- * Designates damper dimension when ordered.
- Pipe train size varies with unit.
- Birdscreen is optional.
- 16 gauge housing.
- Discharge position: 1 FRONT 2 UP 3 DOWN
- D = Damper dim. when ordered and flange on down discharge.
- P and R = Discharge opening when damper is not ordered.
- Damper is shipped loose on down discharge units.

SIZE	A	B	D	E	F	G	H	J	L	M	N	P	R	APPROX. WTS. (LB)
FCBT-110	24.25	58.50	24.00	18.93	1.25	39.00	6.25	36.00	81.00	24.00	12.00	13.62	11.38	1,067
FCBT-115	24.25	58.50	24.00	25.81	1.25	39.00	8.62	36.00	81.00	24.00	12.00	18.62	15.88	1,148
FCBT-118	24.25	58.50	24.00	30.75	1.25	39.00	8.62	36.00	81.00	24.00	12.00	21.88	18.68	1,148
FCBT-120	36.75	73.50	30.00	37.31	1.25	51.00	11.25	48.00	108.00	36.00	18.00	22.75	24.75	1,595
FCBT-122	36.75	73.50	30.00	40.81	1.25	51.00	12.25	48.00	108.00	36.00	18.00	27.25	27.25	1,620

DIMENSIONS ARE NOT TO BE USED FOR CONSTRUCTION.

R27611

Vertical Configuration - 80/20 Recirculation

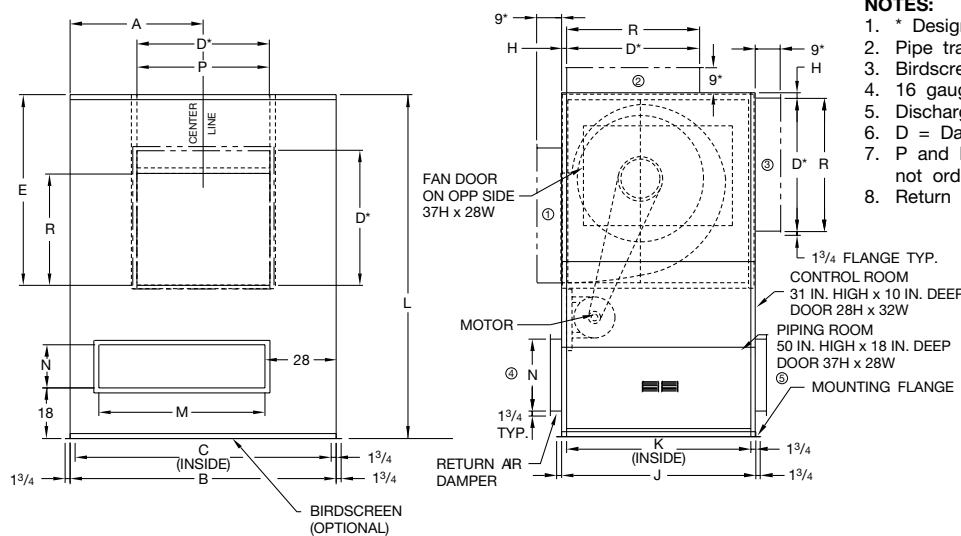

NOTES:

- * Designates damper dimension when ordered.
- Pipe train size varies with unit.
- Birdscreen is optional.
- 16 gauge housing.
- Discharge position: 1 LHORZ 2 UP 3 RHORZ
- D = Damper dimension when ordered.
- P and R = Discharge opening when damper is not ordered.
- Return air position: 4 LEFT 5 RIGHT

SIZE	A	B	C	D	E	F	G	H	J	K	L	M	N	P	R	APPROX. WTS. (LB)
FCBT-110	24.25	58.50	56.00	24.00	18.93	2.25	39.00	1.25	36.00	33.50	81.00	24.00	12.00	13.62	11.38	1,067
FCBT-115	24.25	58.50	56.00	24.00	25.81	2.25	39.00	1.25	36.00	33.50	81.00	24.00	12.00	18.62	15.88	1,148
FCBT-118	24.25	58.50	56.00	24.00	30.75	2.25	39.00	1.25	36.00	33.50	81.00	24.00	12.00	21.88	18.68	1,148
FCBT-120	36.75	73.50	71.00	30.00	37.31	3.25	51.00	1.25	48.00	45.50	108.00	36.00	18.00	22.75	24.75	1,595
FCBT-122	36.75	73.50	71.00	30.00	40.81	3.25	51.00	1.25	48.00	45.50	108.00	36.00	18.00	27.25	27.25	1,620

DIMENSIONS ARE NOT TO BE USED FOR CONSTRUCTION.

R27609

Single Fan Model FCBT – Size 127-136

Direct-Fired Gas Air Make-up Unit

Horizontal Configuration - 100% Outside Air

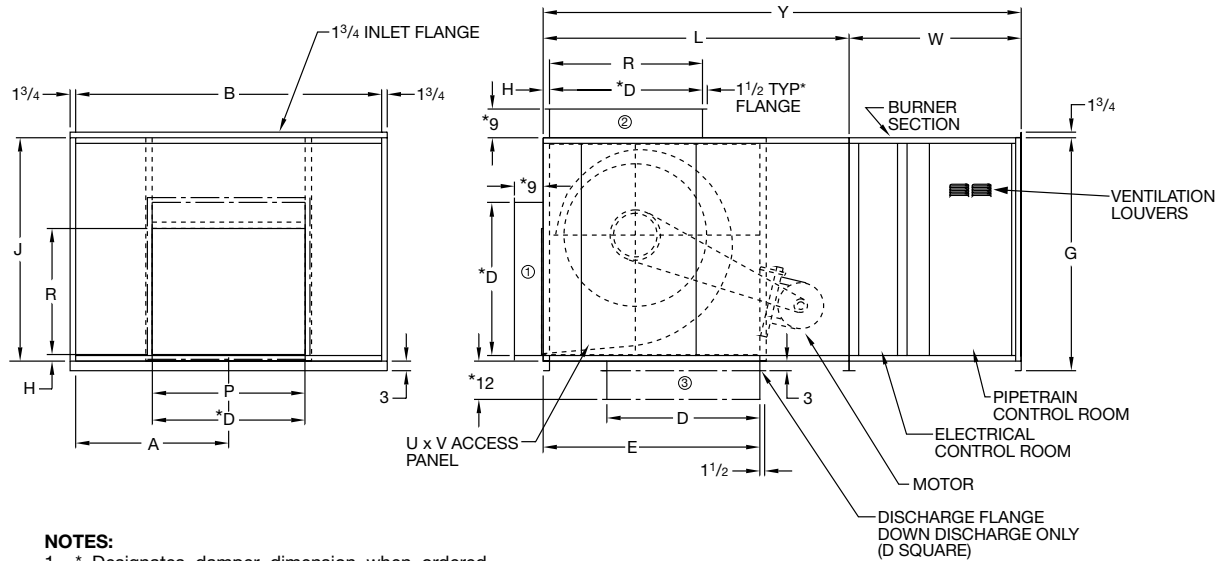

- NOTES:**
- * Designates damper dimension when ordered.
 - Discharge position: 1 FRONT 2 UP 3 DOWN
 - Damper is shipped loose on down discharge units.

SIZE	A	B	D	E		G	H	J	L	P	R	U	V	W	Y	APPROX. WTS. (LB)
				UP/DN	HORZ											
FCBT-127	36.75	73.50	36.00	50.75	40.94	63.13	2.00	60.13	84.00	26.75	34.25	40.00	40.00	60.00	144.00	2,500
FCBT-130-A	36.75	73.50	42.00	54.75	44.12	63.13	2.00	60.13	84.00	28.75	36.75	40.00	40.00	60.00	144.00	2,550
FCBT-130-B	48.75	97.50	42.00	54.75	44.12	63.13	2.00	60.13	84.00	36.75	36.75	40.00	40.00	60.00	144.00	2,600
FCBT-136	48.75	97.50	48.00	59.00	50.50	63.13	2.00	60.13	96.00	42.75	42.94	40.00	40.00	60.00	156.00	2,950

DIMENSIONS ARE NOT TO BE USED FOR CONSTRUCTION.

R27224H

Vertical Configuration - 100% Outside Air

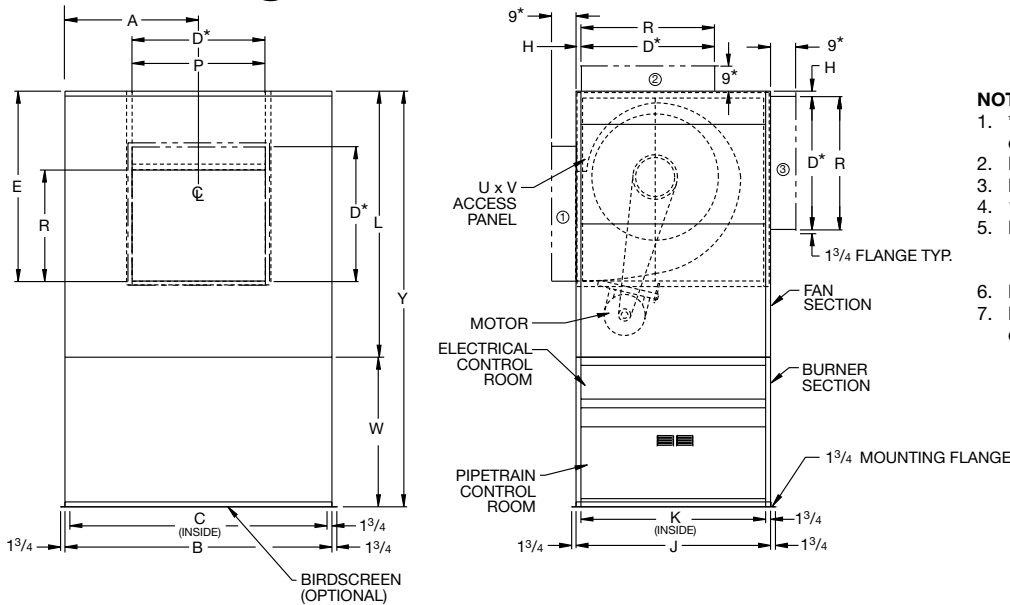

- NOTES:**
- * Designates damper dimension when ordered.
 - Pipe train size varies with unit.
 - Birdscreen is optional.
 - 16 gauge housing.
 - Discharge position: 1 LHORZ 2 UP 3 RHORZ
 - D = Damper dimension when ordered.
 - P and R = Discharge opening when damper is not ordered.

SIZE	A	B	C	D	E	H	J	K	L	P	R	U	V	W	Y	APPROX. WTS. (LB)
FCBT-130-A	36.75	73.50	70.00	42.00	54.75	2.00	60.13	56.63	84.00	28.75	36.75	40.00	40.00	60.00	144.00	2,550
FCBT-130-B	48.75	97.50	94.00	42.00	54.75	2.00	60.13	56.63	84.00	36.75	36.75	40.00	40.00	60.00	144.00	2,600
FCBT-136	48.75	97.50	94.00	48.00	59.00	2.00	60.13	56.63	96.00	42.75	42.94	40.00	40.00	60.00	156.00	2,950

DIMENSIONS ARE NOT TO BE USED FOR CONSTRUCTION.

R27305H

Single Fan Model FCBT – Size 127-136 Direct-Fired Gas Air Make-up Unit

Horizontal Configuration - 80/20 Recirculation

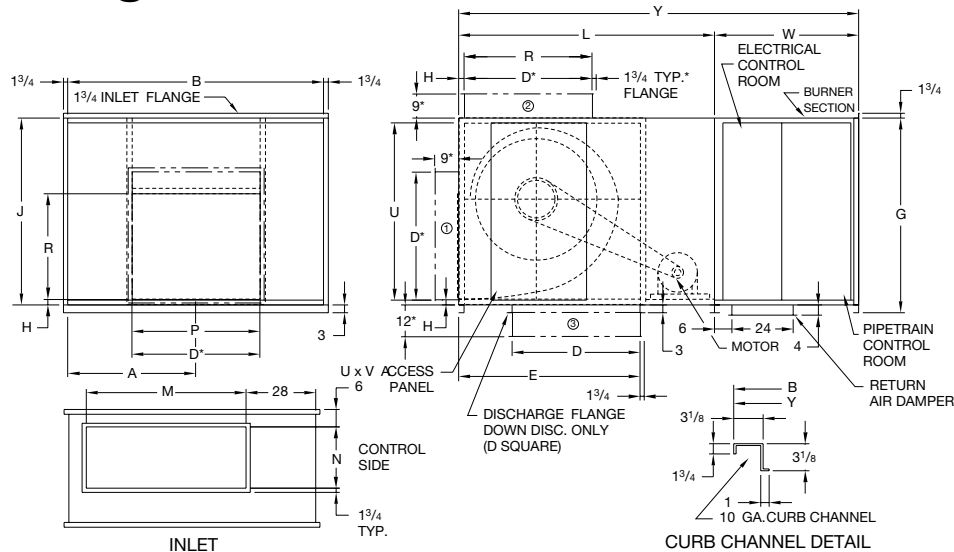

NOTES:

1. * Designates damper dimension when ordered.
2. Pipe train size varies with unit.
3. Birdscreen is optional.
4. 16 gauge housing.
5. Discharge position: 1 FRONT 2 UP 3 DOWN
6. D = Damper dim. when ordered and flange on down discharge.
7. P and R = Discharge opening when damper is not ordered.
8. Damper is shipped loose on down discharge units.
9. Unit built as one piece.

SIZE	A	B	D	E		G	H	J	L	M	N	P	R	U	V	W	Y	APPROX. WTS. (LB)
				UP/DN	HORZ													
FCBT-127	36.75	73.50	36.00	50.75	40.94	63.13	2.00	60.13	84.00	36.00	24.00	26.75	34.25	40.00	40.00	60.00	144.00	2,600
FCBT-130-A	36.75	73.50	42.00	54.75	44.12	63.13	2.00	60.13	84.00	36.00	24.00	28.75	36.75	40.00	40.00	60.00	144.00	2,650
FCBT-130-B	48.75	97.50	42.00	54.75	44.12	63.13	2.00	60.13	84.00	60.00	24.00	36.75	36.75	40.00	40.00	60.00	144.00	2,700
FCBT-136	48.75	97.50	48.00	59.00	50.50	63.13	2.00	60.13	96.00	60.00	24.00	42.75	42.94	40.00	40.00	60.00	156.00	3,100

DIMENSIONS ARE NOT TO BE USED FOR CONSTRUCTION.

R27315G

Vertical Configuration - 80/20 Recirculation

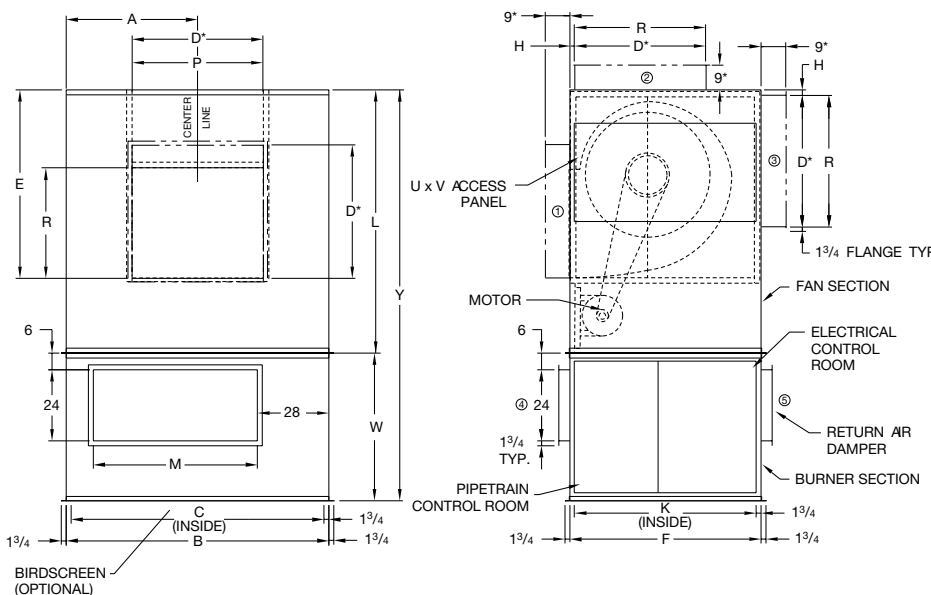

NOTES:

1. * Designates damper dimension when ordered.
2. Pipe train size varies with unit.
3. Birdscreen is optional.
4. 16 gauge housing.
5. Discharge position: 1 LHORZ 2 UP 3 RHORZ
6. D = Damper dimension when ordered.
7. P and R = Discharge opening when damper is not ordered.
8. Return air position: 4 LEFT 5 RIGHT
9. Fan and burner sections split for shipping.

SIZE	A	B	C	D	E	H	J	K	L	M	N	P	R	U	V	W	Y	APPROX. WTS. (LB)
FCBT-130-A	36.75	73.50	70.00	42.00	54.75	2.00	60.12	56.63	84.00	36.00	24.00	28.75	36.25	40.00	40.00	60.00	144.00	2,475
FCBT-130-B	48.75	97.50	94.00	42.00	54.75	2.00	60.12	56.63	84.00	60.00	24.00	36.75	36.75	40.00	40.00	60.00	144.00	2,550
FCBT-136	48.75	97.50	94.00	48.00	59.00	2.00	60.12	56.63	96.00	60.00	24.00	42.75	42.94	40.00	40.00	60.00	156.00	2,987

DIMENSIONS ARE NOT TO BE USED FOR CONSTRUCTION.

R27317H

Single Fan Model BIBT Direct-Fired Gas Air Make-up Unit

Horizontal Configuration - 100% Outside Air

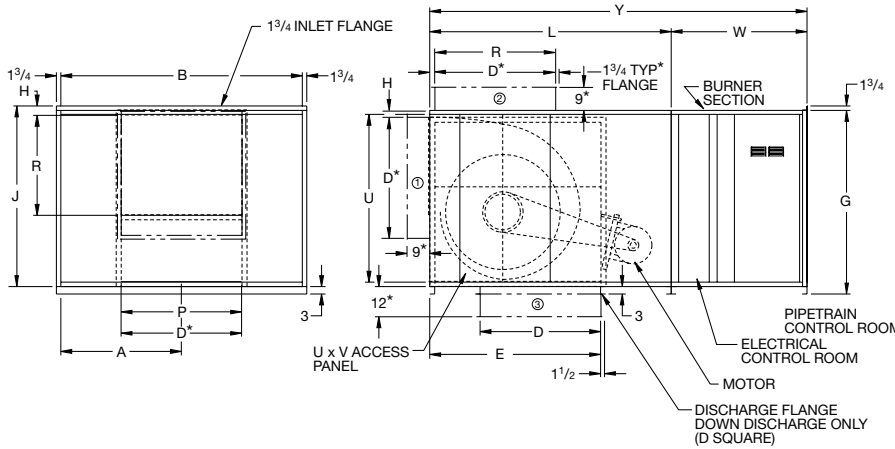

NOTES:

- * Designates damper dimension when ordered.
- Pipe train size varies with unit.
- Birdscreen is optional.
- 16 gauge housing.
- Discharge position: 1 FRONT
2 UP
3 DOWN
- D = Damper dimension when ordered and flange on down discharge.
- P and R = Discharge opening when damper is not ordered.
- Damper is shipped loose on down discharge units.

SIZE	A	B	D	E	G	H	J	L	P	R	U	V	W	Y	APPROX. WTS. (LB)
BIBT-116	29.25	58.50	24.00	31.88	39.00	5.38	36.00	—	20.00	20.00	30.00	30.00	—	81.00	1,275
BIBT-122	36.75	73.50	30.00	43.44	51.00	5.81	48.00	—	28.19	28.19	40.00	40.00	—	108.00	1,850
BIBT-125	36.75	73.50	36.00	48.18	63.13	9.06	60.13	84.00	31.56	31.56	40.00	40.00	60.00	144.00	2,500
BIBT-128	48.75	97.50	42.00	54.19	63.13	3.06	60.13	84.00	35.38	35.38	40.00	40.00	60.00	144.00	2,550
BIBT-132	48.75	97.50	42.00	59.38	63.13	2.00	60.13	96.00	40.00	39.69	40.00	40.00	60.00	156.00	2,675
BIBT-135	48.75	97.50	48.00	66.12	71.00	5.13	68.00	96.00	44.81	44.50	40.00	40.00	60.00	156.00	3,100

DIMENSIONS ARE NOT TO BE USED FOR CONSTRUCTION.

R27225D

Vertical Configuration - 100% Outside Air

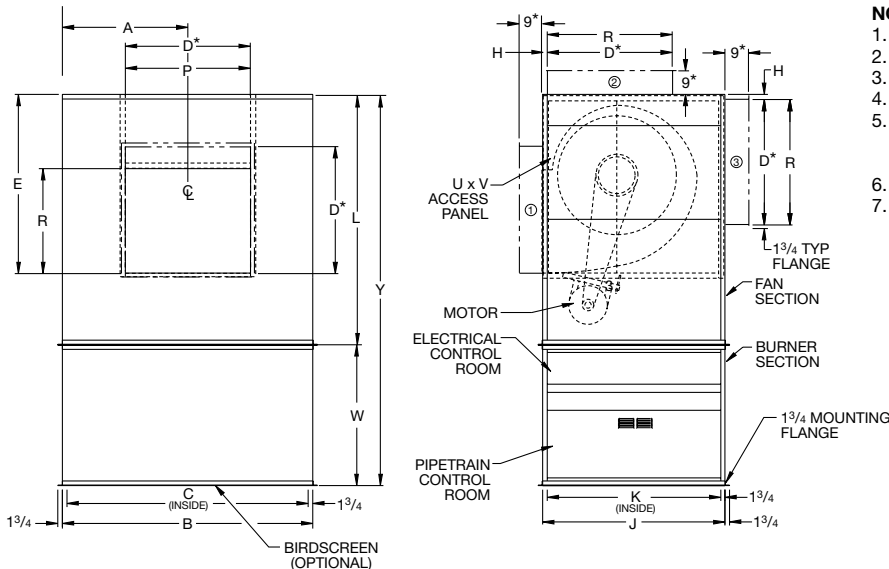

NOTES:

- * Designates damper dimension when ordered.
- Pipe train size varies with unit.
- Birdscreen is optional.
- 16 gauge housing.
- Discharge position: 1 LHORZ
2 UP
3 RHORZ
- D = Damper dimension when ordered.
- P and R = Discharge opening when damper is not ordered.

SIZE	A	B	C	D	E	H	J	K	L	P	R	U	V	W	Y	APPROX. WTS. (LB)
BIBT-116	29.25	58.50	55.00	24.00	30.63	2.00	36.00	33.50	—	20.00	20.00	30.00	30.00	—	81.00	1,275
BIBT-122	36.75	73.50	70.00	30.00	42.19	2.00	48.00	45.50	—	28.19	28.19	40.00	40.00	—	108.00	1,850
BIBT-125	36.75	73.50	70.00	36.00	46.94	2.00	60.13	57.63	84.00	31.56	31.56	40.00	40.00	60.00	144.00	2,500
BIBT-128	36.75	97.50	94.00	42.00	52.94	2.00	60.13	57.63	84.00	35.38	35.38	40.00	40.00	60.00	144.00	2,550
BIBT-132	48.75	97.50	94.00	42.00	58.13	2.00	60.13	57.63	96.00	40.00	39.69	40.00	40.00	60.00	156.00	2,675
BIBT-135	48.75	97.50	94.00	48.00	64.88	2.00	68.00	65.50	96.00	44.81	44.50	40.00	40.00	60.00	156.00	3,100

DIMENSIONS ARE NOT TO BE USED FOR CONSTRUCTION.

R27306C

Single Fan Model BIBT Direct-Fired Gas Air Make-up Unit

Horizontal Configuration - 80/20 Recirculation

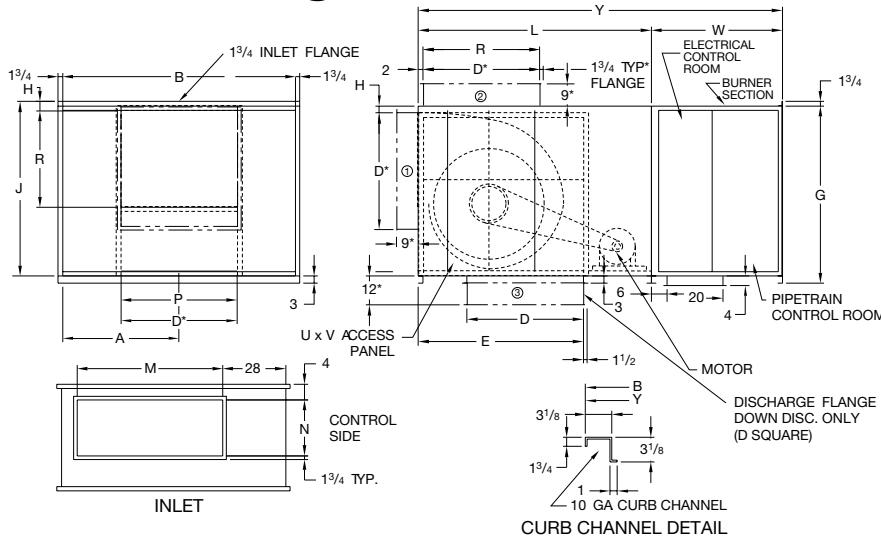

NOTES:

- * Designates damper dimension when ordered.
- Pipe train size varies with unit.
- Birdscreen is optional.
- 16 gauge housing.
- Discharge position: 1 FRONT
2 UP
3 DOWN
- D = Damper dimension when ordered and flange on down discharge.
- P and R = Discharge opening when damper is not ordered.
- Damper is shipped loose on down discharge units.
- One piece construction.

SIZE	A	B	D	E	G	H	J	L	M	N	P	R	U	V	W	Y	APPROX. WTS. (LB)
BIBT-116	29.25	58.50	24.00	30.63	39.00	5.38	36.00	54.00	24.00	12.00	20.00	20.00	30.00	30.00	—	81.00	1,375
BIBT-122	36.75	73.50	30.00	42.19	51.00	5.81	48.00	66.00	36.00	18.00	28.19	28.19	40.00	40.00	—	108.00	1,950
BIBT-125	36.75	73.50	36.00	46.94	63.13	9.06	60.13	84.00	36.00	24.00	31.56	31.56	40.00	40.00	60.00	144.00	2,600
BIBT-128	48.75	97.50	42.00	52.94	63.13	3.06	60.13	84.00	60.00	24.00	35.38	35.38	40.00	40.00	60.00	144.00	2,550
BIBT-132	48.75	97.50	42.00	58.13	63.13	2.00	60.13	96.00	60.00	24.00	40.00	39.69	40.00	40.00	60.00	156.00	2,775
BIBT-135	48.75	97.50	48.00	64.88	71.00	5.13	68.00	96.00	60.00	24.00	44.81	44.50	40.00	40.00	60.00	156.00	3,200

DIMENSIONS ARE NOT TO BE USED FOR CONSTRUCTION.

R27308D

Vertical Configuration - 80/20 Recirculation

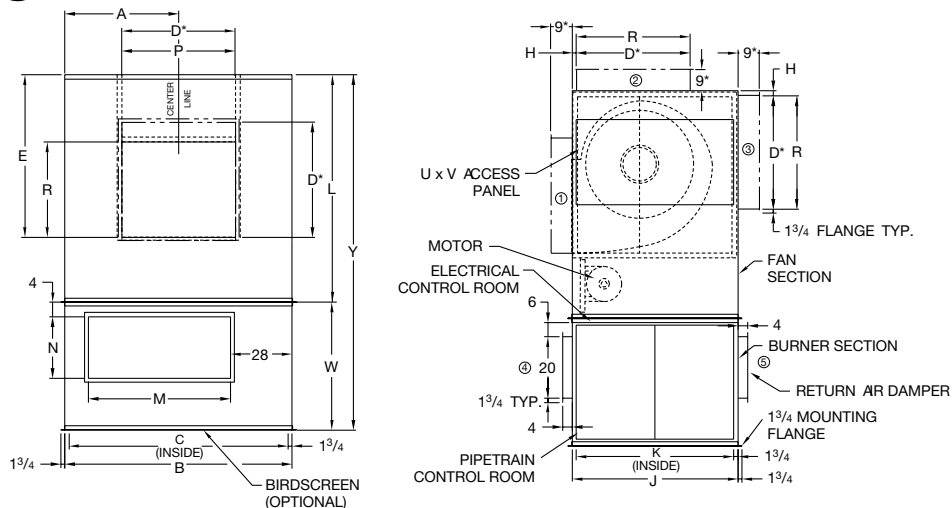

NOTES:

- * Designates damper dimension when ordered.
- Pipe train size varies with unit.
- Birdscreen is optional.
- 16 gauge housing.
- Discharge position: 1 LHORZ 2 UP 3 RHORZ
- D = Damper dimension when ordered.
- P and R = Discharge opening when damper is not ordered.
- Return air position: 4 LEFT 5 RIGHT
- Sizes 116 & 122 are built as one piece.

SIZE	A	B	C	D	E	H	J	K	L	M	N	P	R	U	V	W	Y	APPROX. WTS. (LB)
BIBT-116	29.25	58.50	55.00	24.00	30.63	2.00	36.00	32.50	54.00	24.00	12.00	20.00	20.00	30.00	30.00	60.00	114.00	1,375
BIBT-122	36.75	73.50	70.00	30.00	42.19	2.00	48.00	44.50	66.00	36.00	18.00	28.19	28.19	40.00	40.00	60.00	126.00	1,950
BIBT-125	36.75	73.50	70.00	36.00	46.94	2.00	60.13	56.63	84.00	36.00	24.00	31.56	31.56	40.00	40.00	60.00	144.00	2,600
BIBT-128	48.75	97.50	94.00	42.00	52.94	2.00	60.13	56.63	84.00	60.00	24.00	35.38	35.38	40.00	40.00	60.00	144.00	2,650
BIBT-132	48.75	97.50	94.00	42.00	58.13	2.00	60.13	56.63	96.00	60.00	24.00	40.00	39.69	40.00	40.00	60.00	156.00	2,775
BIBT-135	48.75	97.50	94.00	48.00	64.88	2.00	68.00	66.50	96.00	60.00	24.00	44.81	44.50	40.00	40.00	60.00	156.00	3,200

DIMENSIONS ARE NOT TO BE USED FOR CONSTRUCTION.

R27309C

Accessories – Single Fan Assemblies

V-Bank Filter Cabinet

Standard filter is a disposable type with washable as an option.

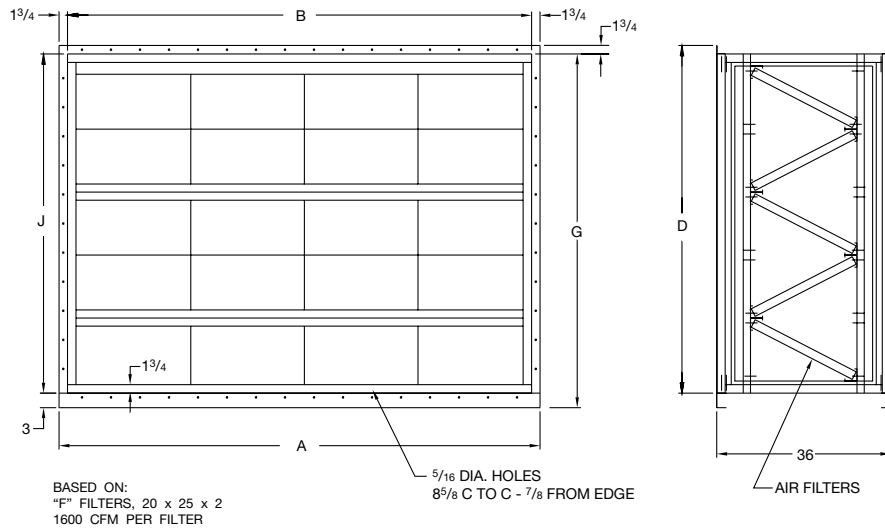

SIZE	A	B	D	F	G	J	APPROX. WTS. (LB)
115, 116 & 118	62.00	58.50	37.75	6	39.00	36.00	225
120, 122 FC & 122 BI	77.00	73.50	49.75	9	51.00	48.00	325
125, 127, 130A	77.00	73.50	57.75	15	63.13	60.13	350
128, 130B	101.00	97.50	61.88	25	63.13	60.13	400
132 & 136	101.00	97.50	61.88	25	63.13	60.13	400
135	101.00	97.50	69.75	25	71.00	68.00	425

DIMENSIONS ARE NOT TO BE USED FOR CONSTRUCTION.

R27228E

Inlet Hood with Removable Bird Screen

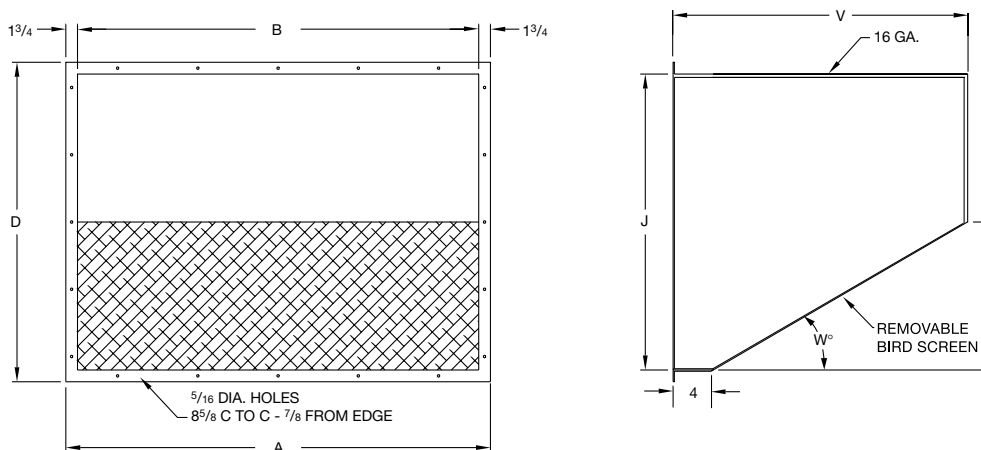

SIZE	A	B	D	J	U	V	W°	APPROX. WTS. (LB)
115, 116, 118	62.00	58.50	39.50	36.00	18.00	35.00	30	180
120, 122 FC, 122 BI	77.00	73.50	51.50	48.00	24.00	45.50	30	265
125, 127, 130A	77.00	73.50	63.63	60.13	30.06	56.00	30	300
128, 130B	101.00	97.50	63.63	60.13	30.06	56.00	30	350
132 & 136	101.00	97.50	63.63	60.13	30.06	56.00	30	350
135	101.00	97.50	71.50	68.00	34.00	62.88	45	400

DIMENSIONS ARE NOT TO BE USED FOR CONSTRUCTION.

R27226E

Accessories – Single Fan Assemblies

Directional Discharge Grille

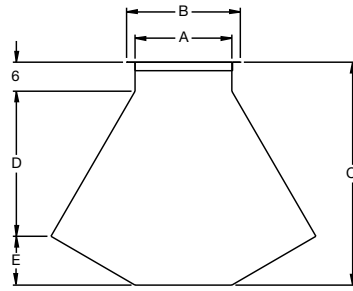

NOTES:

1. Grilles are single or double deflection per order.
2. Assembly requires support from the top or bottom.
3. Single deflection grilles are 80% open area.
4. Double deflection grilles are 65% open area.

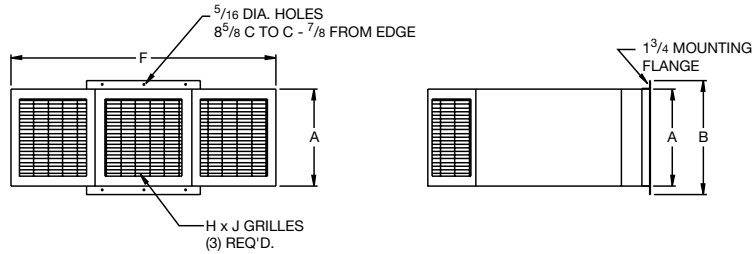

SIZE	A	B	C	D	E	F	H	J	APPROX. WTS. (LB)
115, 116, 118	24.00	27.50	48.00	36.00	12.00	65.56	21.00	21.00	280
120, 122 FC, 122 BI	30.00	33.50	60.00	45.00	15.00	81.97	27.00	27.00	305
125, 127	36.00	39.50	64.00	48.00	16.00	87.44	33.00	29.00	280
128, 130A, 130B, 132	42.00	45.50	64.00	48.00	16.00	87.44	39.00	29.00	305
135, 136	48.00	51.50	96.00	72.00	24.00	131.13	45.00	45.00	459

DIMENSIONS ARE NOT TO BE USED FOR CONSTRUCTION.

R27310C

Air Distributor

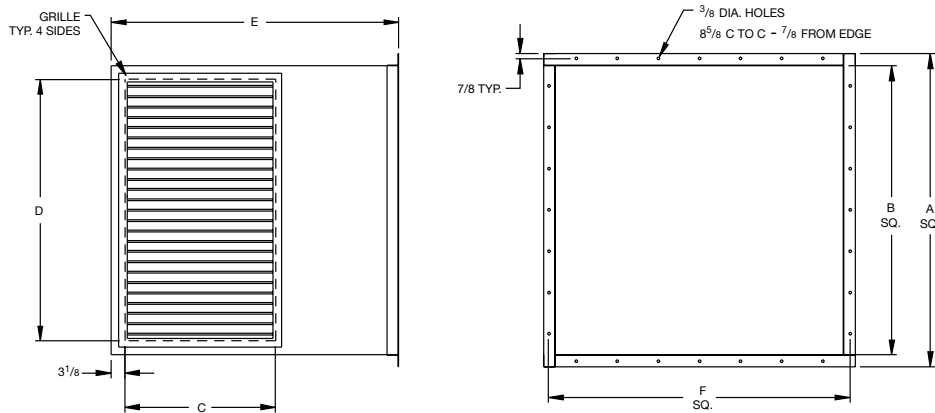

NOTES:

1. Grilles are single or double deflection per order.
2. Single deflection grilles are 80% open area.
3. Double deflection grilles are 65% open area.

SIZE	NOMINAL SIZE	A	B	C	D	E	F	APPROX. WTS. (LB)
115, 116, 118	21 x 21	27.50	24.00	20.50	20.50	36.00	26.00	88
120, 122 FC, 122 BI	27 x 27	33.50	30.00	26.50	26.50	36.00	32.00	114
125, 127	33 x 29	39.50	36.00	28.50	32.50	46.00	38.00	142
128, 130A, 130B, 132	39 x 29	45.50	42.00	28.50	38.50	46.00	44.00	197
135, 136	45 x 45	51.50	48.00	44.50	44.50	56.00	50.00	243

DIMENSIONS ARE NOT TO BE USED FOR CONSTRUCTION.

R27312C

Twin Fan Model FCBT-DW Direct-Fired Gas Air Make-up Unit

Horizontal Configuration - 100% Outside Air

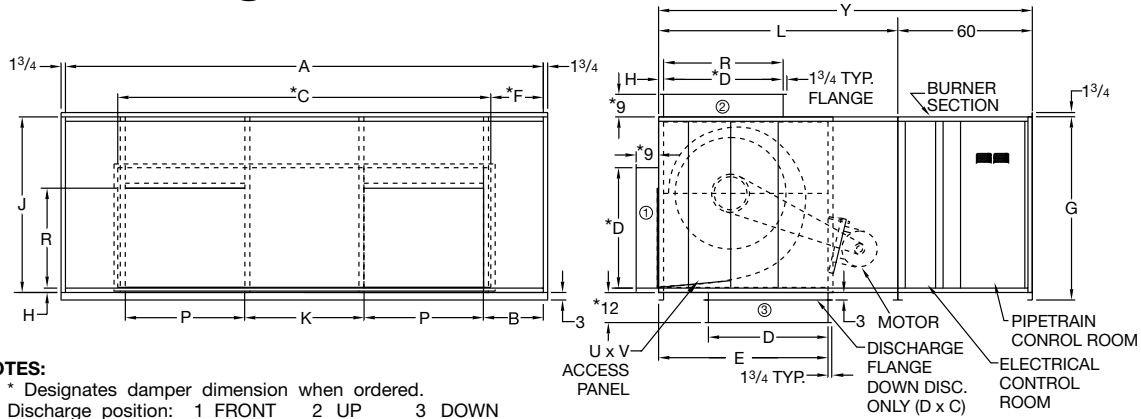

- NOTES:**
 1. * Designates damper dimension when ordered.
 2. Discharge position: 1 FRONT 2 UP 3 DOWN
 3. Damper is shipped loose on down discharge units.

SIZE	A	B	C	D	E		F	G	H	J	K	L	P	R	U	V	Y	APPROX. WTS. (LB)
					HORIZ	UP/DN												
FCBT-222	136.50	30.00	78.00	30.00	33.88	40.88	29.25	51.00	2.12	48.00	22.00	84.00	27.25	27.25	40.00	40.00	144.00	2,900
FCBT-225	136.50	24.50	96.00	36.00	38.00	46.13	20.25	59.00	2.12	48.00	25.00	84.00	31.25	31.25	40.00	40.00	144.00	3,365
FCBT-227	156.00	30.25	108.00	36.00	42.31	50.88	24.00	63.13	2.12	60.13	27.00	84.00	34.25	34.25	40.00	40.00	144.00	4,063
FCBT-230	156.00	26.25	108.00	42.00	45.56	54.94	24.00	63.13	2.19	60.13	30.00	84.00	36.75	36.75	40.00	40.00	144.00	4,586
FCBT-233	171.50	29.50	120.00	48.00	52.13	59.19	25.75	63.13	2.19	60.13	33.00	96.00	39.75	42.94	40.00	40.00	156.00	5,134
FCBT-236	171.50	25.00	132.00	48.00	52.13	59.19	19.75	63.13	2.19	60.13	36.00	96.00	42.75	42.94	40.00	40.00	156.00	5,773

DIMENSIONS ARE NOT TO BE USED FOR CONSTRUCTION.

R27300G

Vertical Configuration - 100% Outside Air

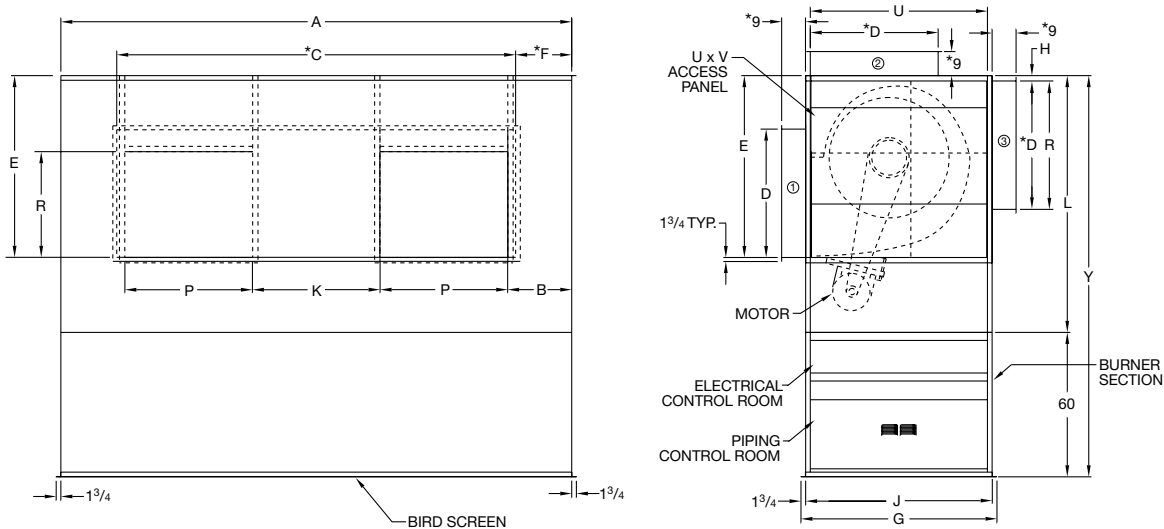

- NOTES:**
 1. * Designates damper dimension when ordered.
 2. Discharge position: 1 LHORZ 2 UP 3 RHORZ

SIZE	A	B	C	D	E	F	G	H	J	K	L	P	R	U	V	Y	APPROX. WTS. (LB)
FCBT-225	136.50	24.50	96.00	36.00	46.19	20.25	51.50	2.12	48.00	25.00	84.00	31.25	31.25	40.00	40.00	144.00	3,365
FCBT-227	156.00	30.25	108.00	36.00	50.94	24.00	63.63	2.12	60.13	27.00	84.00	34.25	34.25	40.00	40.00	144.00	4,063
FCBT-230	156.00	26.25	108.00	42.00	54.94	24.00	63.63	2.12	60.13	30.00	84.00	36.75	36.75	40.00	40.00	144.00	4,586
FCBT-233	171.50	29.50	120.00	48.00	55.00	25.75	63.63	2.19	60.13	33.00	96.00	39.75	42.94	40.00	40.00	156.00	5,134
FCBT-236	171.50	25.00	132.00	48.00	59.25	19.75	63.63	2.19	60.13	36.00	96.00	42.75	42.94	40.00	40.00	156.00	5,773

DIMENSIONS ARE NOT TO BE USED FOR CONSTRUCTION.

R27307J

Twin Fan Model FCBT-DW Direct-Fired Gas Air Make-up Unit

Horizontal Configuration - 80/20 Recirculation

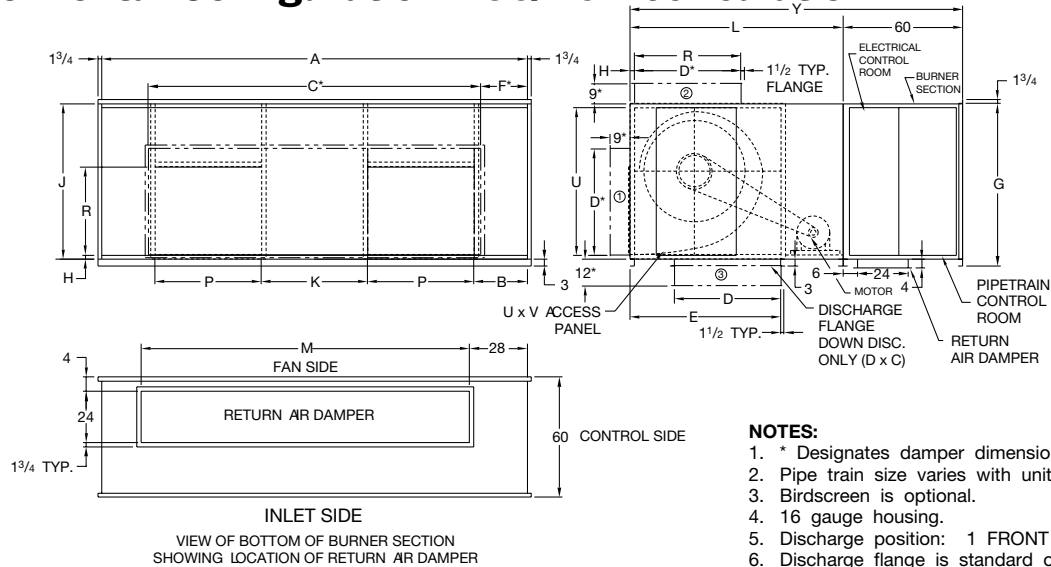

SIZE	A	B	C	D	E		F	G	H	J	K	L	M	P	R	U	V	Y	APPROX. WTS. (LB)
					HORZ	UP/DN													
FCBT-222	136.50	30.00	78.00	30.00	33.88	40.88	29.25	51.00	2.12	48.00	22.00	84.00	78.00	27.25	27.25	40.00	40.00	144.00	2,639
FCBT-225	136.50	24.50	96.00	36.00	38.00	46.13	20.25	51.00	2.12	48.00	25.00	84.00	78.00	31.25	31.25	40.00	40.00	144.00	3,059
FCBT-227	156.00	30.25	108.00	36.00	42.31	50.88	24.00	63.13	2.12	60.13	27.00	84.00	108.00	34.25	34.25	40.00	40.00	144.00	3,694
FCBT-230	156.00	26.25	108.00	42.00	45.56	54.94	24.00	63.13	2.19	60.13	30.00	84.00	108.00	36.75	36.75	40.00	40.00	144.00	4,169
FCBT-233	171.50	29.50	120.00	48.00	52.13	59.19	25.75	63.13	2.19	60.13	33.00	96.00	132.00	39.75	42.94	40.00	40.00	156.00	4,668
FCBT-236	171.50	25.00	132.00	48.00	52.13	59.19	19.75	63.13	2.19	60.13	36.00	96.00	132.00	42.75	42.94	40.00	40.00	156.00	5,249

DIMENSIONS ARE NOT TO BE USED FOR CONSTRUCTION.

R27314F

Vertical Configuration - 80/20 Recirculation

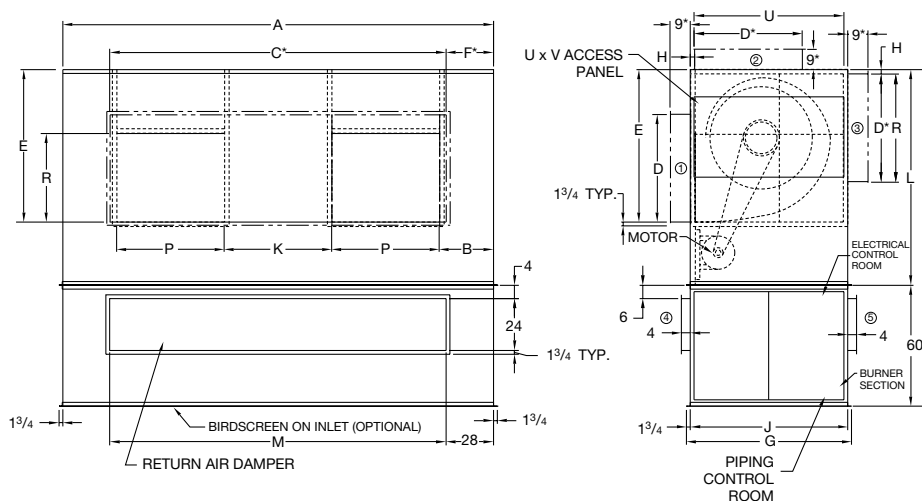

SIZE	A	B	C	D	E	F	G	H	J	K	L	M	P	R	U	V	Y	APPROX. WTS. (LB)
FCBT-225	136.50	24.50	96.00	36.00	46.13	20.25	51.50	2.12	48.00	25.00	84.00	78.00	31.25	31.25	40.00	40.00	144.00	3,059
FCBT-227	156.00	30.25	108.00	36.00	50.88	24.00	63.63	2.12	60.13	27.00	84.00	108.00	34.25	34.25	40.00	40.00	144.00	3,694
FCBT-230	156.00	26.25	108.00	42.00	54.94	24.00	63.63	2.19	60.13	30.00	84.00	108.00	36.75	36.75	40.00	40.00	144.00	4,169
FCBT-233	171.50	29.50	120.00	48.00	59.19	25.75	63.63	2.19	60.13	33.00	96.00	132.00	39.75	42.94	40.00	40.00	156.00	4,668
FCBT-236	171.50	25.00	132.00	48.00	59.19	19.75	63.63	2.19	60.13	36.00	96.00	132.00	42.75	42.94	40.00	40.00	156.00	5,249

DIMENSIONS ARE NOT TO BE USED FOR CONSTRUCTION.

R27316F

Accessories – Twin Fan Assemblies

V-Bank Filter Cabinet

Standard filter is a disposable type with washable as an option.

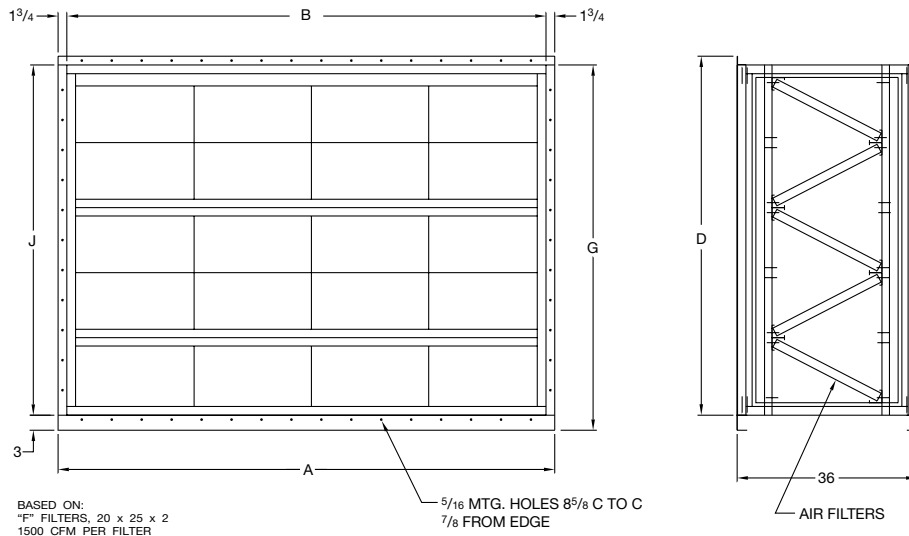

SIZE	A	B	D	F	G	J	APPROX. WTS. (LB)
FCBT-222	140.00	136.50	49.75	28	52.75	48.00	618
FCBT-225	140.00	136.50	49.75	28	52.75	48.00	618
FCBT-227	159.50	156.00	61.88	40	64.88	60.13	727
FCBT-230	159.50	156.00	61.88	40	64.88	60.13	727
FCBT-233	175.00	171.50	61.88	49	64.88	60.13	795
FCBT-236	175.00	171.50	61.88	49	64.88	60.13	795

DIMENSIONS ARE NOT TO BE USED FOR CONSTRUCTION.

R27304E

Inlet Hood with Removable Bird Screen

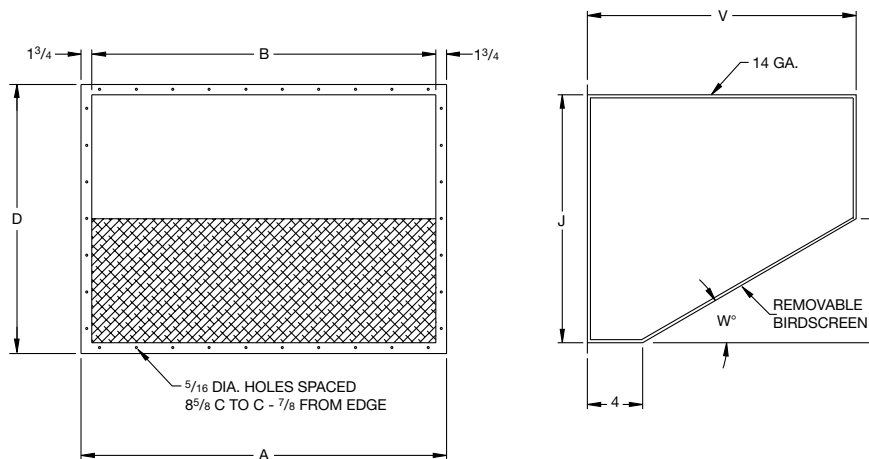

SIZE	A	B	D	J	U	V	W°	APPROX. WTS. (LB)
FCBT-222	140.00	136.50	51.50	48.00	24.00	45.50	30	375
FCBT-225	140.00	136.50	51.50	48.00	24.00	45.50	30	375
FCBT-227	159.50	156.00	63.63	60.13	30.06	56.00	30	425
FCBT-230	159.50	156.00	63.63	60.13	30.06	56.00	30	425
FCBT-233	175.00	171.50	63.63	60.13	30.06	56.00	30	560
FCBT-236	175.00	171.50	63.63	60.13	30.06	56.00	30	560

DIMENSIONS ARE NOT TO BE USED FOR CONSTRUCTION.

R27303F

Accessories – Twin Fan Assemblies

Air Distributor

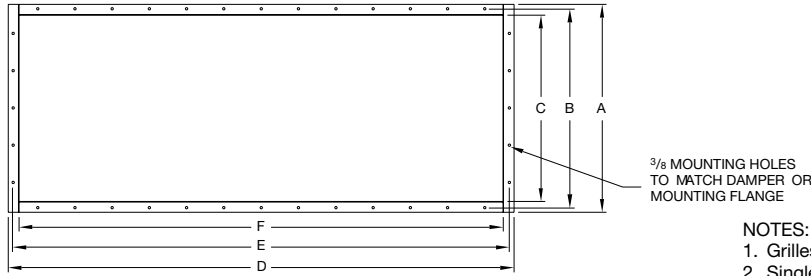

NOTES:

1. Grilles are available as single or double deflection.
2. Single deflection grilles are 80% open area.
3. Double deflection grilles are 65% open area.

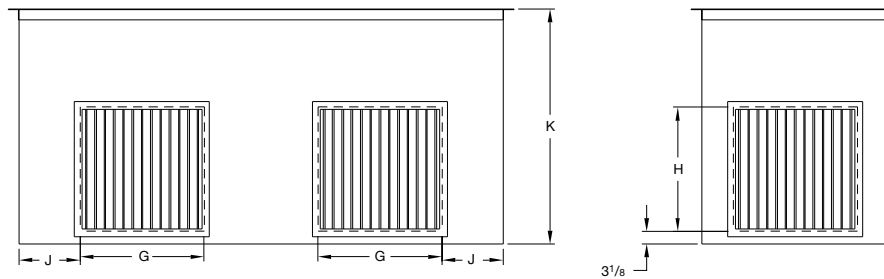

SIZE	NOMINAL SIZE	A	B	C	D	E	F	G	H	J	K	APPROX. WTS. (LB)
222	27 x 23	33.50	32.00	30.00	81.50	80.00	78.00	22.50	26.50	8.25	44.00	298
225	33 x 29	39.50	38.00	36.00	99.50	98.00	96.00	28.50	32.50	9.75	44.00	380
227	33 x 33	39.50	38.00	36.00	111.50	110.00	108.00	32.50	32.50	9.75	44.00	418
230	39 x 33	45.50	44.00	42.00	111.50	110.00	108.00	32.50	38.50	10.75	58.00	553
233	45 x 37	51.50	50.00	48.00	123.50	122.00	120.00	36.50	44.50	11.75	58.00	637
236	45 x 41	51.50	50.00	48.00	135.50	134.00	132.00	40.50	44.50	12.75	58.00	686

DIMENSIONS ARE NOT TO BE USED FOR CONSTRUCTION.

R27313B

Directional Discharge Grille

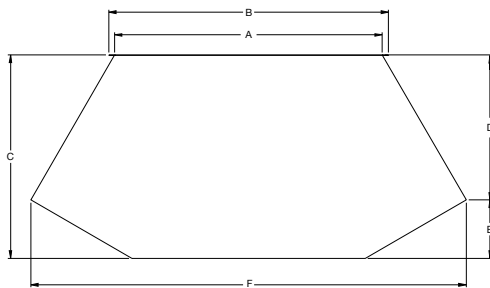

NOTES:

1. Grilles are single or double deflection per order.
2. Assembly requires support from the top or bottom.
3. Single deflection grilles are 80% open area.
3. Double deflection grilles are 65% open area.

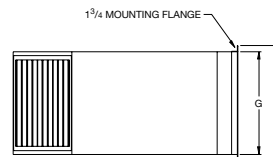
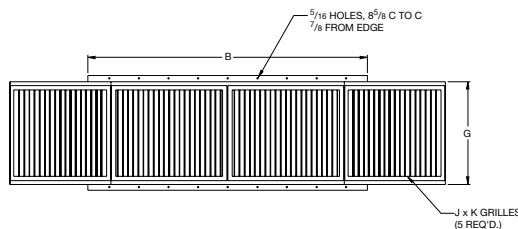

SIZE	A	B	C	D	E	F	G	H	J	K	APPROX. WTS. (LB)
222	78.00	81.50	52.00	39.00	13.00	123.00	30.00	33.50	27.00	23.00	604
225	96.00	99.50	64.00	48.00	16.00	151.44	36.00	39.50	33.00	29.00	517
227	108.00	111.50	72.00	54.00	18.00	170.38	36.00	39.50	33.00	33.00	758
230	108.00	111.50	72.00	54.00	18.00	170.38	42.00	45.50	39.00	33.00	801
233	120.00	123.50	80.00	60.00	20.00	189.25	48.00	51.50	45.00	37.00	971
236	132.00	135.50	88.00	66.00	22.00	208.25	48.00	51.50	45.00	41.00	1,138

DIMENSIONS ARE NOT TO BE USED FOR CONSTRUCTION.

R27311B

Pressure Drop Curves for Accessories

V-Bank Filter Cabinet

Single Fan

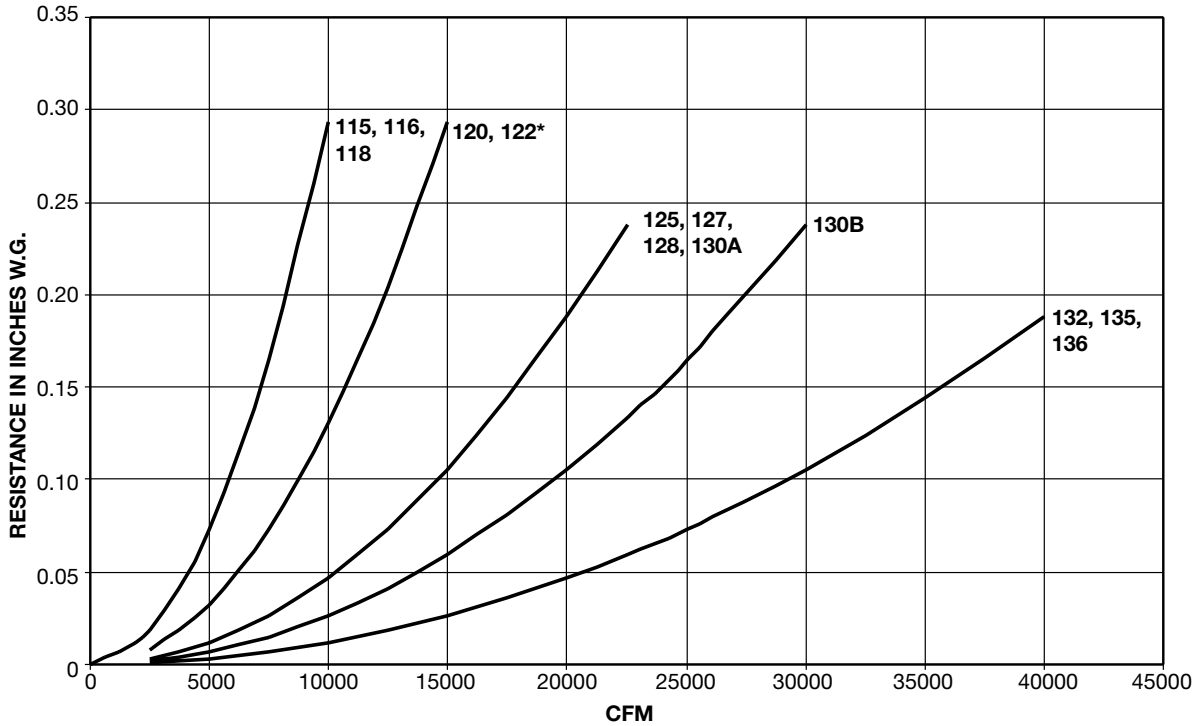

Twin Fan

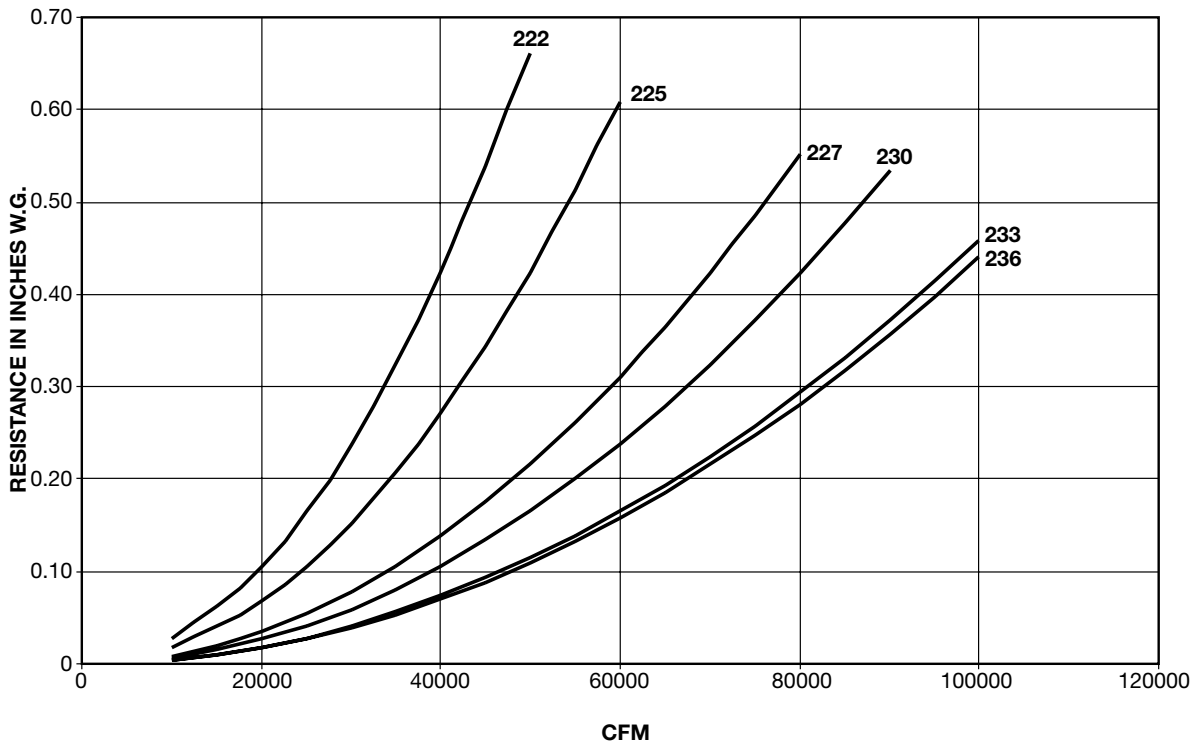

Pressure Drop Curves for Accessories

Parallel Blade Discharge Damper

Single Fan

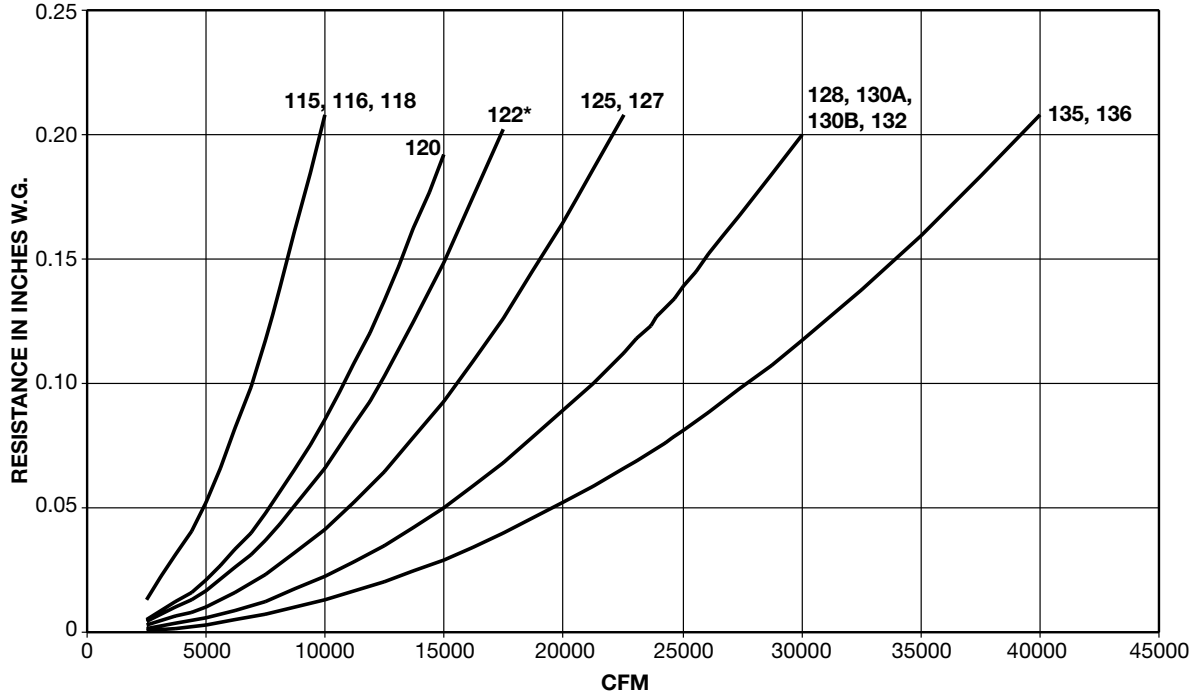

Twin Fan

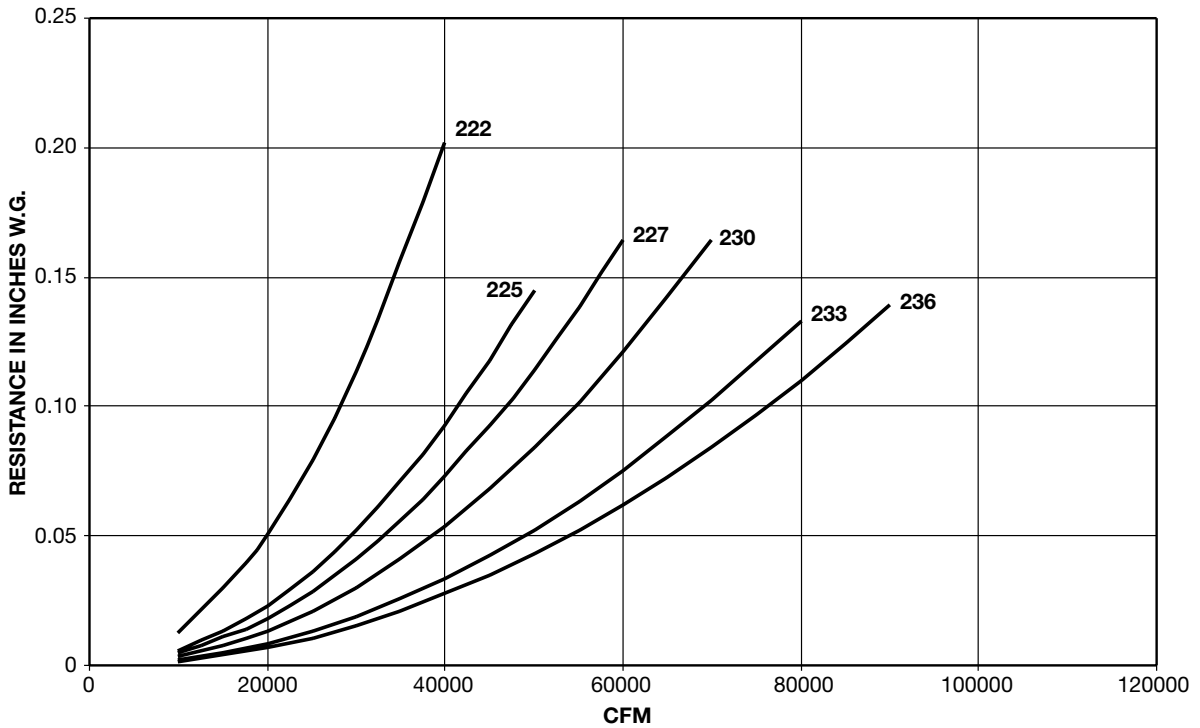

Pressure Drop Curves for Accessories

Directional Discharge Grille

Single Fan

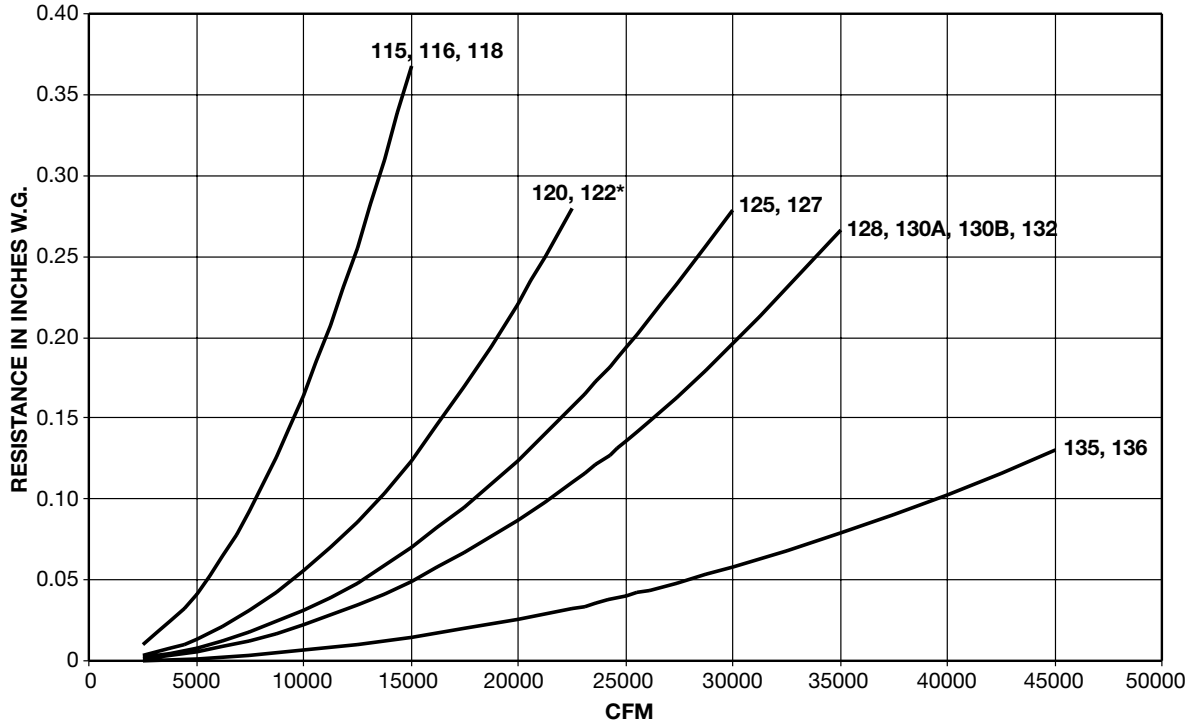

Twin Fan

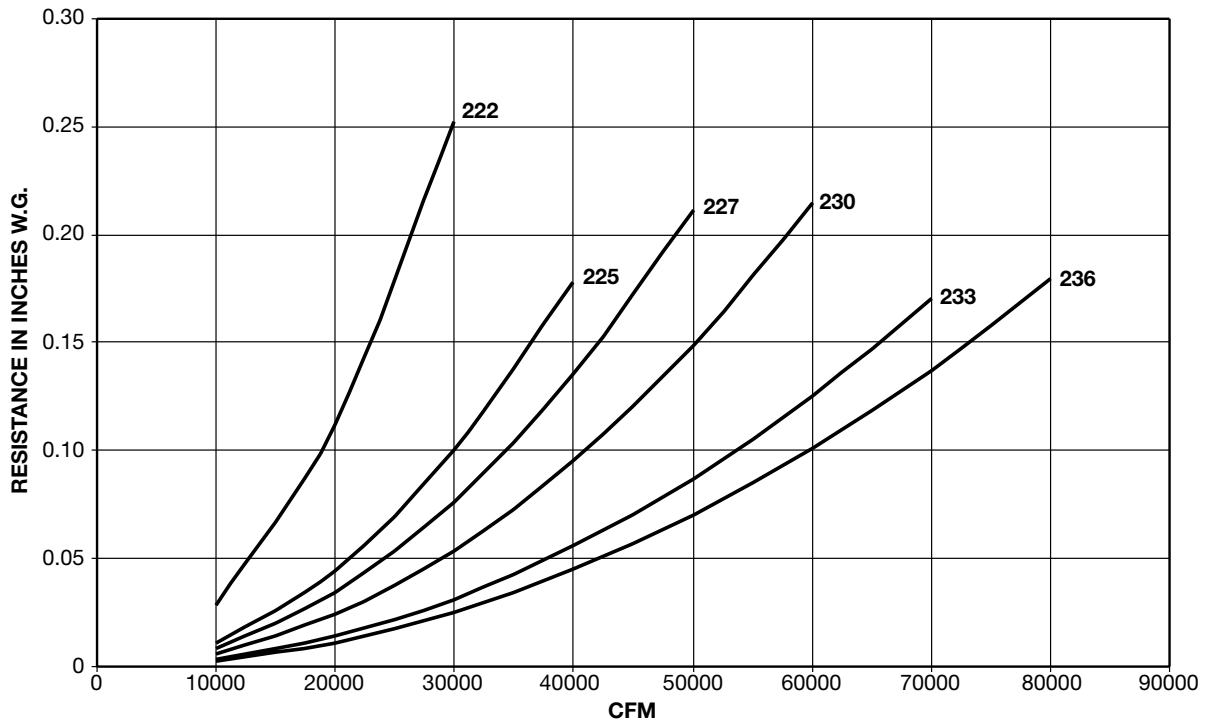

Pressure Drop Curves for Accessories

Air Distributor

Single Fan

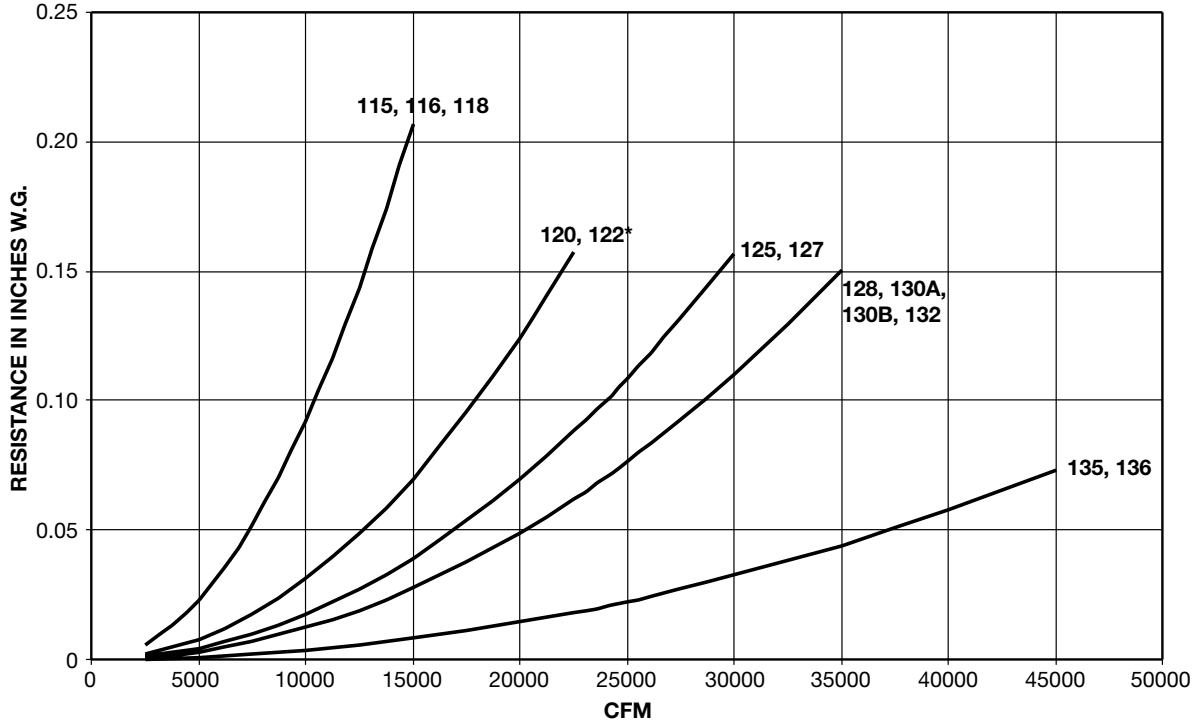

Twin Fan

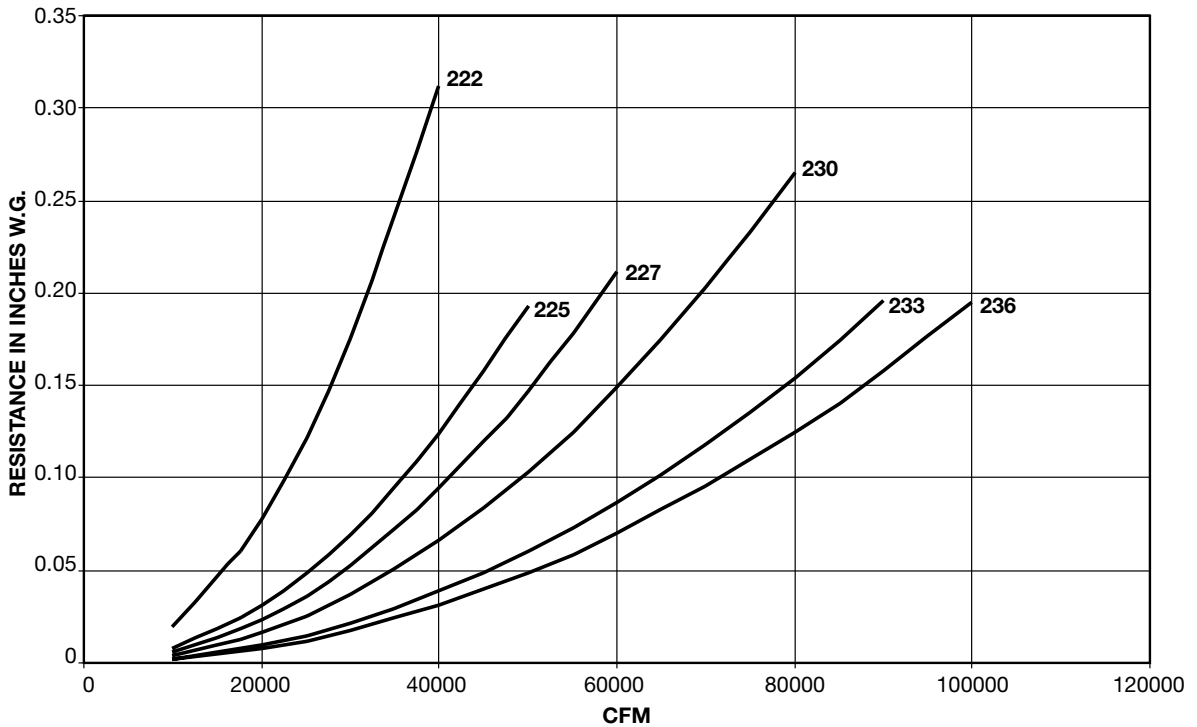

**PROPELLER FANS | TUBEAXIAL & VANEAXIAL FANS | CENTRIFUGAL FANS & BLOWERS | ROOF VENTILATORS
INDUSTRIAL AIR HANDLERS | AIR MAKE-UP | FIBERGLASS FANS | CUSTOM FANS**



AEROVENT
A Twin City Fan Company

AEROVENT 
INDUSTRIAL VENTILATION SYSTEMS

WWW.AEROVENT.COM

5959 Trenton Lane N | Minneapolis, MN 55442 | Phone: 763-551-7500 | Fax: 763-551-7501