

AEROVENT

INDUSTRIAL VENTILATION SYSTEMS

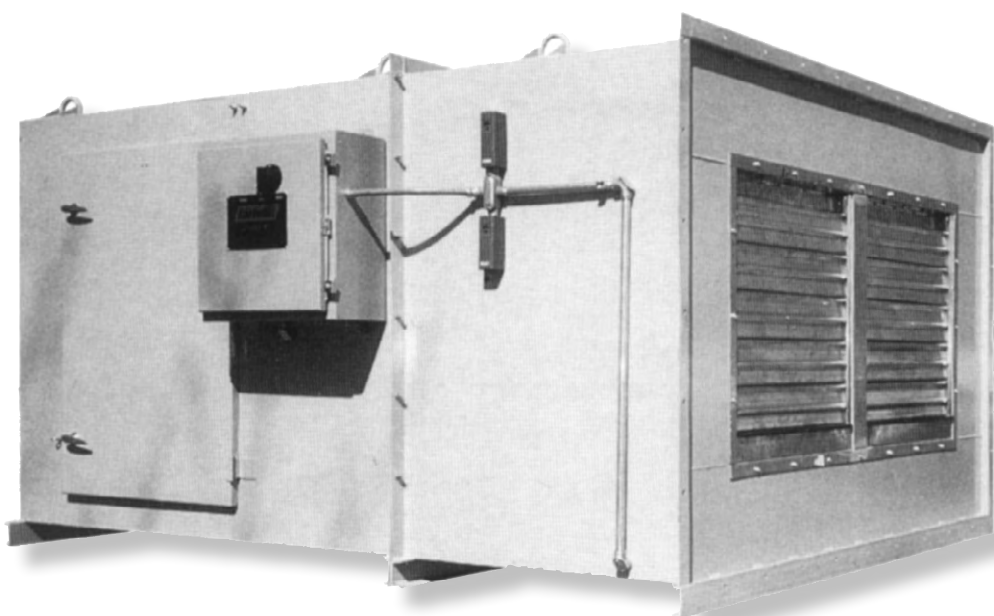

STEAM AIR MAKE-UP

Axial Flow & Centrifugal

Controls

Control Option MA

NEMA 4 enclosure with disconnect switch, motor starter, transformer, relay, terminal strip, low limit thermostat, shutter motor end switch mounted and wired with connection points for additional controls as may be furnished by others.

Control Option MB (to be used with MA)

Temperature controller, modulating valve-motor-linkage, remote operating station for field mounting and interconnection.

Outlet Temperature Control (OTC)

The OTC system is designed to provide a constant average temperature at the discharge of the air make-up unit. The temperature setting is manually adjustable from the operating control station, which is usually mounted at floor level. This station contains the "on-off" control, indicator lamp, and the temperature setting control. The discharge temperature is regulated and maintained by a motor-driven modulating valve. The motor is actuated by electronic sensing devices and an amplifier system, and the valve regulates the flow of steam into the coil.

The electronic modulating system is the best available. It is extremely stable and has no tendency to over-ride on start-up. It will quickly bring the modulating valve to a position of equilibrium and accurately maintain the balance between heat load demand and steam flow.



Remote Operating Station with outlet temperature control (OTC) selector, on-off switch, and indicator lamp at floor level

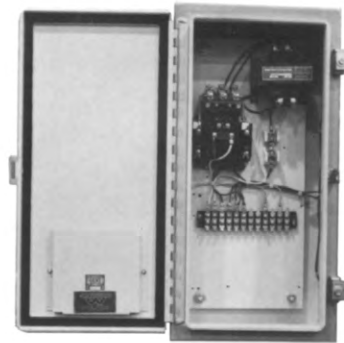

Standardized control panel — NEMA 4

Steam Distributing Tube Coil

Supply and return connections are at the same end. This allows free expansion of the core without transmitting stresses to the tubes, casing, or tube header joints. This design provide good temperature distribution and a maximum of freeze protection. The outer tube is $\frac{5}{8}$ " in diameter and the inner tube is die-formed to be self-centering with steam jets designed to propel the condensate toward the return header.

In operation, the steam enters the supply section at the center of the header marked "A". It passes to the inner distributing tubes and issues evenly from jets throughout the tube length. The condensate is formed in the outer tube and runs down into the upper half of the header and then to the return line connection at "B". Coupling "C" is for the vacuum breaker.

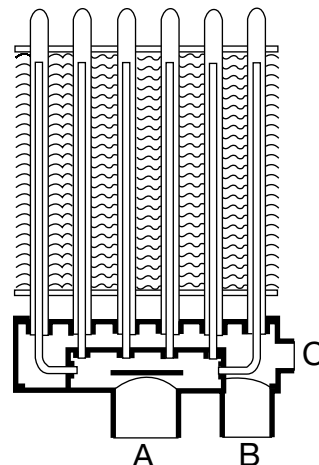

Accessories

Inlet Hood

With turning vanes as shown or fewer turning vanes for use with vee bank filter section. Available for all units.

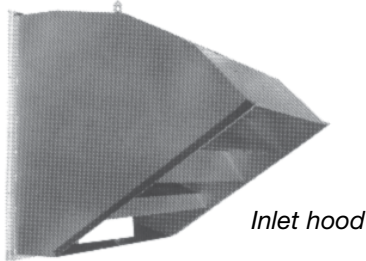

Inlet hood

Filter Section

There are three types available: vee bank, Roll-O-Matic, or flat-bank design. The standard filter is a disposable type with washable available as an option.

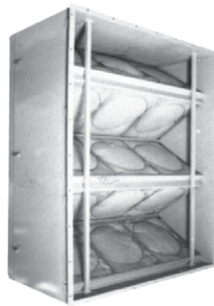

Vee bank filter section

Air Distributor

Features four directional discharge grilles.

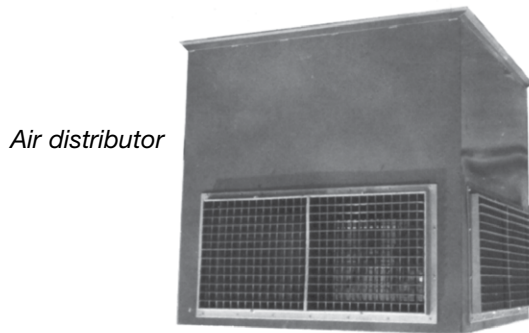

Air distributor

Inlet or Discharge Elbows With Turning Vanes

Inlet elbows for use with propeller units. Discharge elbows fit the propeller units and are adaptable to others.



Directional Discharge Grille

Provides for four-way adjustment of airflow. Cabinet is lined with acoustic material. It is usually used with propeller type units.

Vibration Eliminators

Available for use with all type units. Rubber-in-shear or spring.

Bird Screen

Available for use on all type units.

Service Platform

For convenient access to motor and control enclosure, a sturdily-built service platform is optional for all installations.



Additional Options

The following is a condensed list of additional options. Please contact your Aerovent representative with specific requirements not shown.

- Water or electric heating coil in lieu of steam
- Face and bypass configuration
- Integral face and bypass coil
- Chilled water or DX cooling section
- Process heating applications
- Recirculation mixing box
- High efficiency filtration
- Evaporative air cooler section
- Internal fan vibration isolation
- Galvanized, aluminum or stainless steel construction
- Special paints/coatings
- Double wall insulated construction
- Vertical mounting configuration
- PLC controls
- Variable frequency drive or 2-speed operation
- Custom unit design or controls to meet customer needs

Performance Data — Propeller Fan

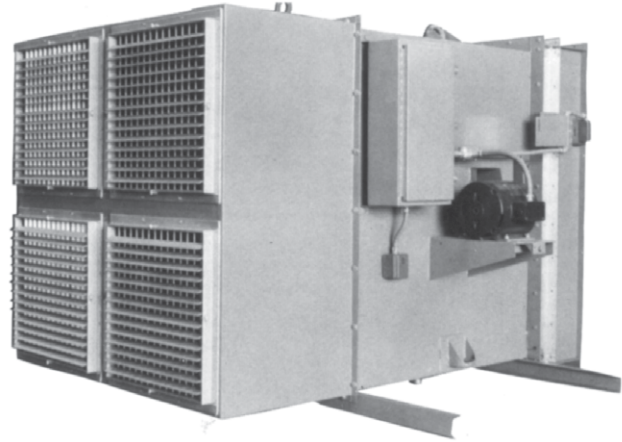

Unit includes fan, coil, vacuum breaker and motorized shutter — assembled.

Discharge grille is optional (see page 3).

For control options, see page 2.

Propeller Fan

CATALOG NUMBER	CFM	EXT. SP	FAN SIZE	FAN RPM	MOTOR HP	TEMP. RISE	BTU/HR (5 PSI STEAM)
S30L422-1052-1	7,000	0	30	1052	1	0-84	711,000
S30L422-1238-1.5	7,000	1/4	30	1238	1 1/2	0-84	711,000
S30L422-1419-3	7,000	1/2	30	1419	3	0-84	711,000
S30L422-1403-3	10,000	0	30	1403	3	0-74	1,070,000
S30L422-1536-3	10,000	1/4	30	1536	3	0-74	1,070,000
S30L422-1668-5	10,000	1/2	30	1668	5	0-74	1,070,000
S36L422-982-2	11,250	0	36	982	2	0-84	918,000
S36L422-1106-3	11,250	1/4	36	1106	3	0-84	918,000
S36L422-1225-5	11,250	1/2	36	1225	5	0-84	918,000
S36L422-1255-5	15,000	0	36	1255	5	0-74	1,225,000
S36L422-1351-5	15,000	1/4	36	1351	5	0-74	1,225,000
S36L422-1444-7.5	15,000	1/2	36	1444	7 1/2	0-74	1,225,000
S42L422-788-2	15,000	0	42	788	2	0-84	1,520,000
S42L422-899-3	15,000	1/4	42	899	3	0-84	1,520,000
S42L422-1004-5	15,000	1/2	42	1004	5	0-84	1,520,000
S42L422-994-5	20,000	0	42	994	5	0-74	1,637,000
S42L422-1081-5	20,000	1/4	42	1008	5	0-74	1,637,000
S42L422-1164-7.5	20,000	1/2	42	1164	7 1/2	0-74	1,637,000
S48L422-759-5	18,750	0	48	759	5	0-84	1,766,000
S48L422-854-5	18,750	1/4	48	854	5	0-84	1,766,000
S48L422-946-7.5	18,750	1/2	48	946	7 1/2	0-84	1,766,000
S48L422-987-7.5	25,000	0	48	987	7 1/2	0-74	2,100,000
S48L422-1062-10	25,000	1/4	48	1062	10	0-74	2,100,000
S48L422-1133-10	25,000	1/2	48	1133	10	0-74	2,100,000
S54L422-650-5	26,250	0	54	650	5	0-84	2,500,000
S54L422-732-5	26,250	1/4	54	732	5	0-84	2,500,000
S54L422-811-7.5	26,250	1/2	54	811	7 1/2	0-84	2,500,000
S54L422-827-7.5	26,250	0	54	827	7 1/2	0-74	3,000,000
S54L422-892-10	26,250	1/4	54	892	10	0-74	3,000,000
S54L422-954-15	26,250	1/2	54	954	15	0-74	3,000,000
S60L422-597-7.5	33,750	0	60	597	7 1/2	0-84	3,200,000
S60L422-670-7.5	33,750	1/4	60	670	7 1/2	0-84	3,200,000
S60L422-738-10	33,750	1/2	60	738	10	0-84	3,200,000
S60L422-785-15	45,000	0	60	785	15	0-74	3,700,000
S60L422-841-15	45,000	1/4	60	841	15	0-74	3,700,000
S60L422-894-15	45,000	1/2	60	894	15	0-74	3,700,000
S72L422-478-7.5	45,000	0	72	478	7 1/2	0-84	4,300,000
S72L422-542-10	45,000	1/4	72	542	10	0-84	4,300,000
S72L422-602-15	45,000	1/2	72	602	15	0-84	4,300,000
S72L422-607-15	60,000	0	72	607	15	0-74	5,000,000
S72L422-657-15	60,000	1/4	72	657	15	0-74	5,000,000
S72L422-705-20	60,000	1/2	72	705	20	0-74	5,000,000

NOTE: Add 1/4" when ordering with filters. BHP does not include belt drive losses.

Dimensional Data — Propeller Fan

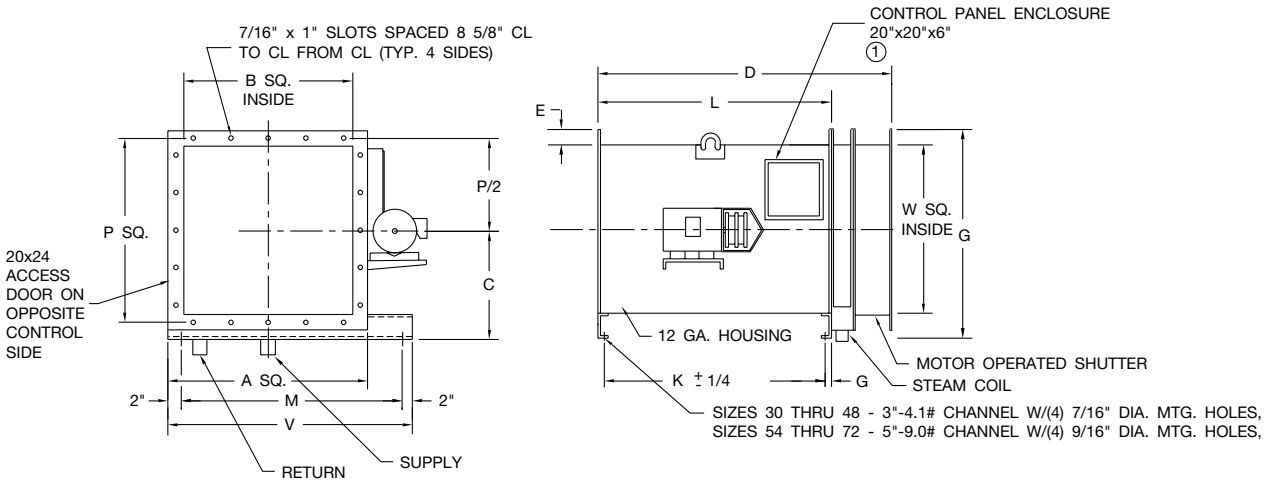

SIZE	A	B	C	D	E	G	K	L	M	P	R	V	W
30	39½	36⅞	21⅜	53	1½	40¾	37⅞	39	47	38	1⅜	51	36
36	45½	42⅞	24⅜	53	1½	46¾	37⅞	39	57	44	1⅜	61	42
42	51½	48⅞	27⅜	53	1½	52¾	37⅞	39	63	50	1⅜	67	48
48	57½	54⅞	30⅜	59	1½	58¾	43⅞	45	71	56	1⅜	75	54
54	71½	68⅞	39⅜	66½	2	75¼	50¼	52½	86	70	1⅞	90	68
60	78½	75⅞	42⅜	66½	2	82¼	50¼	52½	92	77	1⅞	96	75
72	91½	88⅞	49⅜	66½	2	95¼	50¼	52½	108	90	1⅞	112	88

Dimensions are not to be used for construction.

NOTES:

- Panel location may vary from indicated position on various sizes and size of enclosure may change for special modifications.
- Welded construction with internal reinforcing.
- NEMA 12 control panel enclosure.
- Liquid-tight conduit.
- Propeller is 4, 6 or 7 blade as required per catalog no.

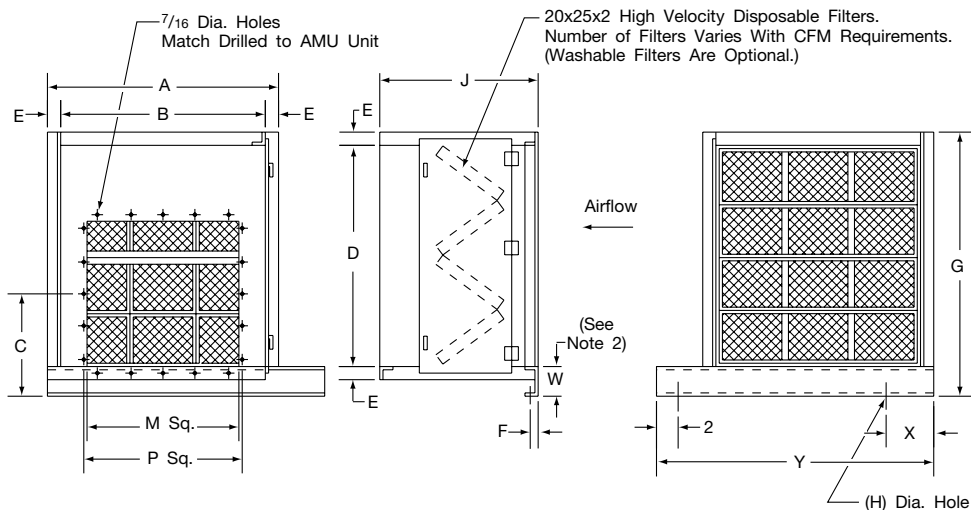

SIZE	A	B	C	D	E	F	G	H	J	M	P	W	X	Y	GA.
30	52⅞	49½	21⅞	42⅞	1⅞	1⅜	46¾	⅞	33	36⅞	38	3	8¾	57¾	14
36	62⅞	59	24⅞	68⅞	1⅞	1⅜	72¾	⅞	35	42⅞	44	3	10½	69½	14
42	62⅞	59	27⅞	74	1⅞	1⅜	78⅞	⅞	35	48⅞	50⅞	3	7½	72½	14
48	81⅞	78⅞	30⅞	80	1⅞	1⅜	84¾	⅞	35	54⅞	56⅞	3	14⅞	87⅞	12
54	82⅞	78⅞	39⅞	94½	2⅞	1⅞	101¾	⅞	35	68⅞	70⅞	5	7⅞	95⅞	12
60	102½	98¼	42⅞	101½	2⅞	1⅞	108¾	⅞	35	75⅞	77⅞	5	13⅞	107⅞	12
72	122¾	118½	49⅞	114¾	2⅞	1⅞	122	⅞	35	88⅞	90⅞	5	17⅞	127⅞	12

Dimensions are not to be used for construction.

Performance Data — DW Centrifugal Fan

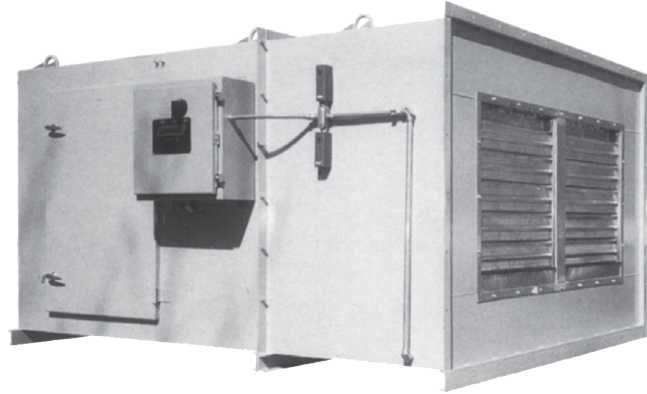

Unit includes fan, coil, vacuum breaker and motorized shutter — assembled.

For control options, see page 2.

FC-DW Centrifugal (Forward Curved Blade)

CATALOG NUMBER	CFM	TEMP. RISE	BTU/HR (5 PSI) STEAM)	OV	EXTERNAL STATIC PRESSURE									
					0"		1/2"		1"		1 1/2"		2"	
					RPM	BHP	RPM	BHP	RPM	BHP	RPM	BHP	RPM	BHP
SCDW-400-FC	3,750	0-84	343,000	1678	438	0.47	635	0.90	805	1.42	961	2.04	1110	2.76
	5,000	0-84	458,000	2238	557	1.04	709	1.54	848	2.13	977	2.80	1102	3.55
SCDW-560-FC	7,500	0-84	687,000	1754	326	0.96	450	1.69	563	2.67	666	3.82	758	5.05
	10,000	0-84	915,000	2339	413	2.07	509	2.95	600	4.01	687	5.26	769	6.65
SCDW-630-FC	11,250	0-84	1,000,000	2045	354	2.15	448	3.29	535	4.70	617	6.35	693	8.16
	15,000	0-84	1,370,000	2727	456	4.81	527	6.15	597	7.79	663	9.58	727	11.58
SCDW-710-FC	15,000	0-84	1,370,000	2158	293	2.88	369	4.17	439	5.66	506	7.42	568	9.33
	20,000	0-84	1,830,000	2878	383	6.64	440	8.19	497	10.07	550	11.99	602	14.16
SCDW-800-FC	18,750	0-84	1,717,000	1795	212	2.75	284	4.48	349	6.58	409	9.03	466	11.72
	25,000	0-84	2,288,000	2394	272	6.14	327	8.21	380	10.67	430	13.41	478	16.47
SCDW-900-FC	22,000	0-84	2,014,000	1733	189	2.74	258	4.59	321	6.96	382	9.82	446	13.18
	30,000	0-84	2,747,000	2364	250	6.60	302	9.02	352	11.65	399	14.75	445	18.25
SCDW-1000-FC	26,000	0-84	2,380,000	1711	168	3.05	232	5.18	291	7.95	347	11.26	406	15.22
	35,000	0-84	3,200,000	2304	220	7.15	269	9.91	316	12.99	360	16.49	417	15.99

Add 1/4" when ordering with filters. BHP shown does not include belt drive losses.

BI-DW Centrifugal (Backward Inclined Blade)

CATALOG NUMBER	CFM	TEMP. RISE	BTU/HR (5 PSI) STEAM)	OV	EXTERNAL STATIC PRESSURE									
					1/2"		1"		1 1/2"		2"		2 1/2"	
					RPM	BHP	RPM	BHP	RPM	BHP	RPM	BHP	RPM	BHP
SCDW-400-FC	3,750	0-84	343,000	1329	1119	0.84	1289	1.26	1432	1.68	1560	2.11	1687	2.60
	5,000	0-84	458,000	1773	1338	1.46	1494	2.01	1627	2.56	1745	3.10	1859	3.67
SCDW-560-BI	7,500	0-84	687,000	1464	813	1.57	936	2.31	1044	3.08	1136	3.85	1223	4.67
	10,000	0-84	915,000	1953	983	2.81	1085	3.74	1180	4.71	1268	5.71	1350	6.74
SCDW-630-BI	11,250	0-84	1,000,000	1811	880	3.25	975	4.32	1063	5.46	1143	6.61	1215	7.76
	15,000	0-84	1,370,000	2415	1097	6.32	1173	7.70	1246	9.12	1315	10.57	1381	12.07
SCDW-710-BI	15,000	0-84	1,370,000	1989	799	4.05	872	5.32	941	6.63	1007	8.00	1070	9.42
	20,000	0-84	1,830,000	2652	1015	8.19	1071	9.77	1127	11.47	1180	13.17	1231	14.88
SCDW-800-BI	18,750	0-84	1,717,000	1663	580	4.26	647	5.87	711	7.61	772	9.46	821	11.01
	25,000	0-84	2,288,000	2218	721	8.10	775	10.18	826	12.29	875	14.48	923	16.78
SCDW-900-BI	22,000	0-84	2,014,000	1595	498	4.69	561	6.59	622	8.65	680	10.78	734	12.83
	30,000	0-84	2,747,000	2175	631	9.44	680	11.95	727	14.52	772	17.13	817	19.92
SCDW-1000-BI	26,000	0-84	2,380,000	1550	438	5.21	497	7.46	553	9.87	607	12.39	658	14.89
	35,000	0-84	3,200,000	2087	547	10.02	593	12.92	637	15.90	679	18.94	722	22.28
SCDW-1120-BI	35,000	0-84	3,320,000	1708	431	8.19	480	11.20	527	14.39	573	17.79	616	21.12
	40,000	0-84	3,662,000	1952	478	11.13	522	14.53	564	18.04	605	21.73	645	25.58
SCDW-1250-BI	45,000	0-84	4,120,000	1810	407	11.14	449	14.92	490	18.97	529	23.14	567	27.46
	50,000	0-84	4,578,000	2012	444	14.42	482	18.54	519	22.85	555	27.36	585	31.36

Add 1/4" when ordering with filters. BHP shown does not include belt drive losses.

NOTE: Capacities to 100,000 CFM available. Contact Aerovent representative with requirements.

©2006 Aerovent, Twin City Fan Companies, Ltd
 Catalog illustrations cover the general appearance of Aerovent products at the time of publication and we reserve the right to make changes in design and construction at anytime without notice.

Dimensional Data — DW Centrifugal Fan

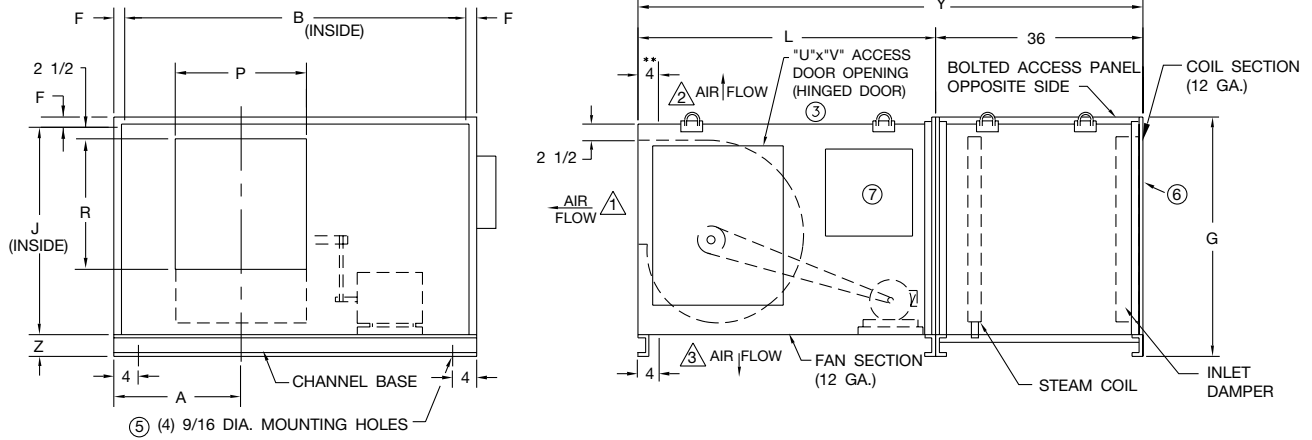

SIZE	A	B	F	G	J	L	P	R	U	V	Y	Z
400	23 1/4	63	1 5/8	42 5/8	38	54	21 1/2	17 19/32	24	30	90	3
560	31 1/2	80	1 5/8	51 5/8	47	64	29 29/32	24 21/32	27	36	100	3
630	35 3/4	82	2 1/8	57 3/8	52 1/4	66	33 19/32	27 23/32	27	48	102	3
710	38	98	2 1/8	65 3/4	58 1/2	82	34 5/8	29	32	54	118	5
800	42 1/4	112	2 1/8	72 1/8	64 7/8	84	46 11/16	35 1/8	34	58 1/4	120	5
900	47 7/8	112	2 1/8	79 1/8	72 5/8	93	51 13/16	38 11/16	38	58 1/4	127	5
1000	53 1/2	120	2 1/8	88 3/8	80 1/8	96	57 3/16	42 5/8	40	58 1/4	132	6
1120	59 3/4	132	2 1/8	97 3/8	89 1/8	104	63 1/8	47 1/8	27	71 3/4	140	6
1250	66 1/8	144	2 1/8	107	98 3/4	110	69 7/16	51 15/16	27	71 3/4	146	6

Dimensions are not to be used for construction.

NOTES:

1. Welded construction with internal reinforcing.
2. Liquid-tight conduit.
3. Opening located on shaft centerline for shaft and wheel removal.
4. Discharge position: 1 Front 2 Top 3 Bottom
5. For isolator mounting dimensions, see DWG. R25735-00.
6. Birdscreen is optional.
7. 20x20 NEMA 4 control enclosure when MA package is purchased.

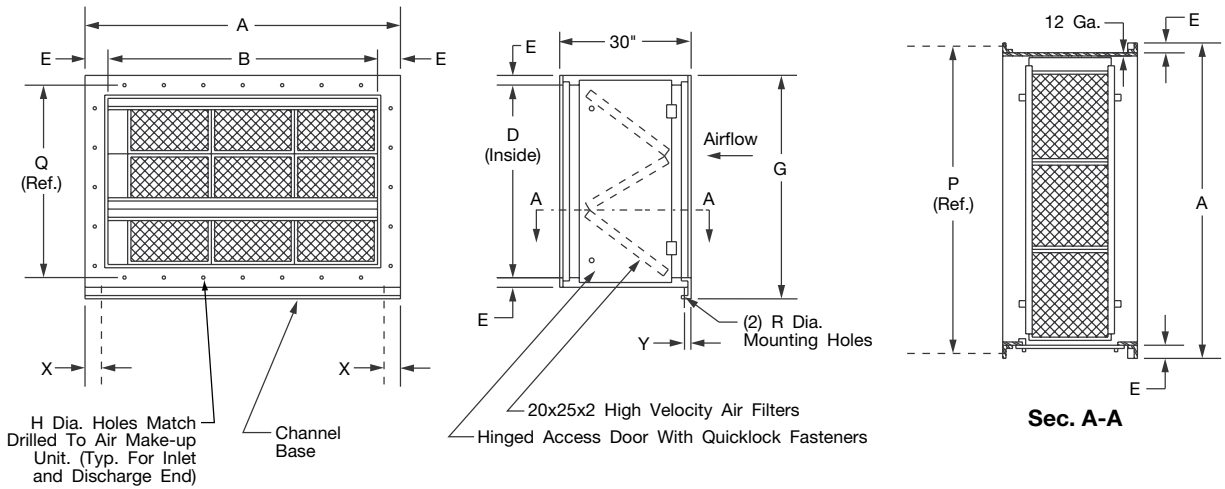

SIZE	A	B	D	E	G	H	P	Q	R	W	X	Y
400	66 1/4	63	40	1 5/8	44 1/2	7/16	64 3/4	39 3/4	7/16	3	3 1/2	1 3/16
560	83 1/4	80	49	1 5/8	53 1/2	7/16	81 3/4	48 3/4	7/16	3	3 1/2	1 3/16
630	86	81 3/4	54 1/4	2 1/8	59 1/4	7/16	84	54 1/2	7/16	3	4	1 3/16
710	102 1/4	98	60 1/2	2 1/8	67 5/8	9/16	100 1/4	60 3/4	9/16	5	4	1 1/8
800	116 1/4	112	66 7/8	2 1/8	74	9/16	114 1/4	67 1/8	9/16	5	4	1 1/8
900	116 1/4	112	74 5/8	2 1/8	81 3/4	9/16	114 1/4	74 7/8	9/16	5	4	1 1/8
1000	124 1/4	120	82 1/8	2 1/8	90 3/8	9/16	122 3/8	82 1/2	9/16	6	4	1 1/8
1120	136 1/4	132	91 1/8	2 1/8	99 3/8	9/16	134 3/8	91 1/2	9/16	6	4	1 1/8
1250	148 1/4	144	100 3/4	2 1/8	109	9/16	146 3/8	101 1/8	9/16	6	4	1 1/8

Dimensions are not to be used for construction.

**PROPELLER FANS | TUBEAXIAL & VANEAXIAL FANS | CENTRIFUGAL FANS & BLOWERS | ROOF VENTILATORS
INDUSTRIAL AIR HANDLERS | AIR MAKE-UP | FIBERGLASS FANS | CUSTOM FANS**



AEROVENT
A Twin City Fan Company

AEROVENT 
INDUSTRIAL VENTILATION SYSTEMS

WWW.AEROVENT.COM

5959 Trenton Lane N | Minneapolis, MN 55442 | Phone: 763-551-7500 | Fax: 763-551-7501